

Getac

M230
USER'S MANUAL

May 2009

TRADEMARKS

All brand and product names are trademarks or registered trademarks of their respective companies.

NOTE

The information in this manual is subject to change without notice.



ENERGY STAR® is a government program that offers businesses and consumers energy-efficient solutions, making it easy to save money while protecting the environment for future generations.

Please reference ENERGY STAR® related information from www.energystar.gov.

As an ENERGY STAR® Partner, MiTAC Technology Corporation has determined that this product meets the ENERGY STAR® guidelines for energy efficiency.

An ENERGY STAR® qualified computer uses 70 % less electricity than computers without enabled power management features.

Earning the ENERGY STAR®

- When every home office is powered by equipment that has earned the ENERGY STAR®, the change will keep over 289 billion pounds of greenhouse gases out of the air.
- If left inactive, ENERGY STAR® qualified computers enter a low-power mode and may use 15 watts or less. New chip technologies make power management features more reliable, dependable, and user-friendly than even just a few years ago.
- Spending a large portion of time in low-power mode not only saves energy, but helps equipment run cooler and last longer.
- Businesses that use ENERGY STAR® enabled office equipment may realize additional savings on air conditioning and maintenance.

- Over its lifetime, ENERGY STAR® qualified equipment in a single home office (e.g., computer, monitor, printer, and fax) can save enough electricity to light an entire home for more than 4 years.
- Power management (“sleep settings”) on computers and monitors can result in much savings annually.

Remember, saving energy prevents pollution

Because most computer equipment is left on 24 hours a day, power management features are important for saving energy and are an easy way to reduce air pollution. By using less energy, these products help lower consumers’ utility bills, and prevent greenhouse gas emissions.



LEARN MORE AT
energystar.gov

Table of Contents

| | | |
|------------------|---|------------|
| Chapter 1 | Getting Started | 1-1 |
| | Getting the Computer Running..... | 1-2 |
| | Unpacking | 1-2 |
| | Connecting to AC Power | 1-2 |
| | Opening and Closing the Cover | 1-4 |
| | Turning On and Off the Computer | 1-5 |
| | Taking a Look at the Computer..... | 1-6 |
| | Front Components..... | 1-6 |
| | Rear Components | 1-8 |
| | Right-Side Components..... | 1-9 |
| | Left-Side Components..... | 1-10 |
| | Bottom Components | 1-11 |
| | Top-open Components..... | 1-12 |
| Chapter 2 | Operating Your Computer | 2-1 |
| | Starting and Stopping the Computer..... | 2-2 |
| | Starting the Computer | 2-2 |
| | Stopping the Computer | 2-2 |
| | Using the Keyboard | 2-4 |
| | Typewriter Keys | 2-4 |
| | Cursor-Control Keys..... | 2-5 |
| | Numeric Keypad | 2-5 |
| | Function Keys..... | 2-6 |
| | Fn Key | 2-6 |
| | Hot Keys | 2-6 |
| | Using the Touchpad..... | 2-9 |
| | Configuring the Touchpad..... | 2-11 |

| | |
|--|------|
| Using the Touchscreen (Optional) | 2-12 |
| Using the Hard Disk Drive | 2-14 |
| Using the Optical Drive..... | 2-15 |
| Installing the Optical Drive | 2-16 |
| Inserting and Removing a Disc | 2-17 |
| Using the Video Features | 2-19 |
| Configuring the Display Modes..... | 2-20 |
| Using the Audio Features..... | 2-21 |
| Connecting Audio Devices | 2-22 |
| Using the Communication Features..... | 2-23 |
| Using the LAN | 2-23 |
| Using the Wireless LAN (Optional)..... | 2-24 |
| Using the Modem | 2-27 |
| Using the Wireless Modem (Optional)..... | 2-28 |
| Using the Bluetooth Feature (Optional) | 2-29 |
| Using the GPS Feature (Optional)..... | 2-32 |
| Turning On/Off the GPS | 2-32 |

Chapter 3 Managing Power 3-1

| | |
|--|------|
| AC Adapter..... | 3-2 |
| Battery Pack..... | 3-3 |
| Charging the Battery Pack | 3-3 |
| Initializing the Battery Pack..... | 3-4 |
| Checking the Battery Level | 3-4 |
| Replacing the Primary Battery Pack | 3-5 |
| Installing the Secondary Battery Pack..... | 3-6 |
| Battery Low Signals and Actions | 3-7 |
| Power Management | 3-9 |
| Hibernation Mode | 3-10 |
| Power-Saving Tips..... | 3-11 |

Chapter 4 Expanding Your Computer 4-1

| | |
|--------------------------------------|-----|
| Connecting an External Monitor | 4-2 |
| Connecting a USB Device | 4-3 |
| Connecting a Parallel Device..... | 4-4 |
| Connecting a Serial Device | 4-5 |
| Connecting an IR Device..... | 4-6 |

| | | |
|------------------|--|------------|
| | Connecting an IEEE 1394B Device (Optional) | 4-8 |
| | Using PC Cards..... | 4-9 |
| | Inserting and Removing a PC Card | 4-9 |
| | System Memory Upgrade | 4-11 |
| Chapter 5 | Using BIOS Setup and System Recovery..... | 5-1 |
| | BIOS Setup | 5-2 |
| | When to Use BIOS Setup | 5-2 |
| | Main Menu..... | 5-4 |
| | Advanced Menu..... | 5-5 |
| | Security Menu | 5-6 |
| | Boot Menu | 5-8 |
| | Exit Menu | 5-10 |
| | System Recovery..... | 5-11 |
| Chapter 6 | Installing Software Drivers and Utilities | 6-1 |
| | How to Use the Driver Disc | 6-2 |
| | Installation for Windows XP | 6-3 |
| | Drivers on the First Page | 6-3 |
| | Drivers on the Second Page | 6-5 |
| | Installation for Windows Vista..... | 6-9 |
| | Drivers on the First Page | 6-9 |
| | Drivers on the Second Page | 6-12 |
| | Using Special Utilities..... | 6-15 |
| | Touchscreen Utility | 6-15 |
| | OSD for Hot Key Operations..... | 6-16 |
| Chapter 7 | Caring for the Computer..... | 7-1 |
| | Protecting the Computer | 7-2 |
| | Using an Anti-Virus Strategy | 7-2 |
| | Using the Password | 7-2 |
| | Using the Cable Lock..... | 7-3 |
| | Taking Care of the Computer | 7-4 |
| | Location Guidelines | 7-4 |
| | General Guidelines | 7-4 |
| | Cleaning Guidelines..... | 7-5 |
| | Battery Pack Guidelines..... | 7-5 |

| | |
|--|------------|
| Touchscreen Guidelines..... | 7-6 |
| When Traveling..... | 7-8 |
| Chapter 8 Troubleshooting | 8-1 |
| Preliminary Checklist..... | 8-2 |
| Solving Common Problems | 8-3 |
| Battery Problems | 8-3 |
| Bluetooth Problems..... | 8-3 |
| Display Problems..... | 8-4 |
| Hardware Device Problems..... | 8-5 |
| Hard Disk Drive Problems..... | 8-5 |
| Infrared Problems..... | 8-6 |
| Keyboard, Mouse, and Touchpad Problems..... | 8-7 |
| LAN Problems..... | 8-7 |
| WLAN Problems | 8-7 |
| Modem Problems..... | 8-9 |
| Optical Drive Problems..... | 8-9 |
| PC Card Problems..... | 8-10 |
| Power Management Problems | 8-11 |
| Printer Problems | 8-11 |
| Software Problems | 8-12 |
| Sound Problems | 8-12 |
| Startup Problems | 8-13 |
| Other Problems..... | 8-13 |
| Resetting the Computer | 8-14 |
| Appendix A Specifications..... | A-1 |
| Appendix B Regulatory Information | B-1 |
| On the Use of the System..... | B-2 |
| Class B Regulations..... | B-2 |
| Safety Notices | B-3 |
| On the Use of the RF Device | B-6 |
| USA and Canada Safety Requirements and Notices | B-6 |
| European Union CE Marking and Compliance Notices.... | B-9 |

Chapter 1

Getting Started

Congratulations on purchasing this rugged notebook computer.

This chapter first tells you step by step how to get the computer up and running. Then, you will find a section briefly introducing the external components of the computer.

Getting the Computer Running

This section guides you through the procedures for getting the computer ready for operation.

Unpacking

After unpacking the shipping carton, you should find these standard items:

- Notebook computer
- Accessories:
 - AC adapter (100~240 VAC, 50/60 Hz)
 - AC power cord (US/CE/UK/SA)
 - Driver disc
 - Car adapter (option)
 - Extra battery pack (option)
 - Touchscreen pen (option)
 - Vehicle docking (option)
 - Office docking (option)

Inspect all the items. If any item is damaged or missing, notify your dealer immediately.

Keep the shipping carton and packing materials in case you need to ship or store the computer in the future.

Connecting to AC Power

The computer operates either on the external AC power or internal battery power. It is suggested that you use AC power when you start up the computer for the very first time.

CAUTION: Use only the AC adapter included with your computer. Using other AC adapters may damage the computer.

NOTE:

Power Supply Cord: optional) Detachable, minimum 1.5 m long. Listed, rated minimum 125 V, 7 A, having a 2/18 AWG, type SVT flexible cord. One end terminates with a parallel blade, molded-on, attachments plug with a 7 A, 125 V (NEMA 1-15P) configuration; other end terminates with a molded-on appliance coupler.

Alternative: (optional) Detachable, maximum 4.5 m (14.76 ft) long. Listed, rated minimum 250 V, 6 A, having a 3/18 AWG, type SVT flexible cord. One end terminates with a Tandem blade, grounding, listed molded-on, attachments plug with a 6 A, 250 V (NEMA 6-15P) configuration; other end terminates with a molded-on appliance coupler.

1. Make sure that the computer is turned off.
2. Plug the DC cord of the AC adapter to the power connector of the computer (❶).
3. Plug the female end of the AC power cord to the AC adapter and the male end to an electrical outlet (❷).

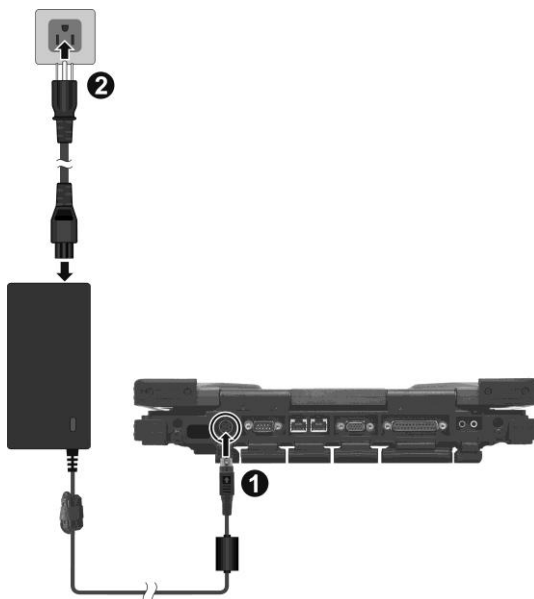

4. When the AC adapter is connected, power is being supplied from the electrical outlet to the AC adapter and onto your computer. Now, you are ready to turn on the computer.

CAUTION:

- When you disconnect the AC adapter, disconnect from the electrical outlet first and then from the computer. A reverse procedure may damage the AC adapter or the computer.
- When unplugging the connector, always hold the plug head. Never pull on the cord.

NOTE: When the AC adapter is connected, it also charges the battery pack. For information on using battery power, see Chapter 3.

Opening and Closing the Cover

CAUTION: Be gentle when opening and closing the cover. Opening it vigorously or slamming it shut could damage the computer.

Open the top cover by pulling on the cover latch and lifting up the cover. You can tilt the cover forward or backward for optimal viewing clarity.

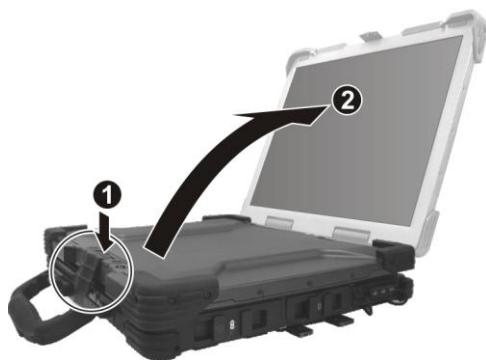

Turning On and Off the Computer

Turning On

1. Make sure that the computer is connected to AC power.
2. Press the power button ().



3. Each time the computer is turned on, it performs a Power-On Self Test (POST), and the operating system such as Windows should start.

Turning Off

To turn off the computer power, use the “Shut Down” command of your operating system.

NOTE: There are other ways you can stop the computer so that you will be back to where you left off when you next turn on the computer. (See “Stopping the Computer” in Chapter 2 for information.)

CAUTION: If you have to turn the computer on again immediately after turning it off, wait for at least five seconds. Turning the computer off and on rapidly can damage it.





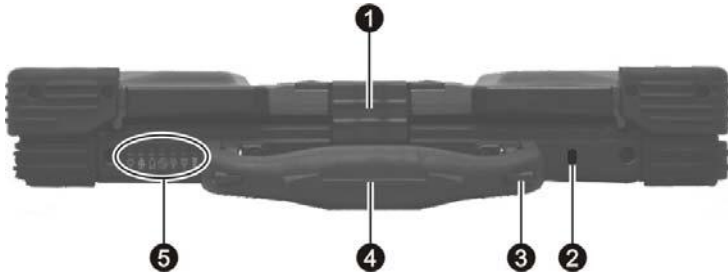

Taking a Look at the Computer

NOTE: Depending on the model you purchased, the appearance of your computer may not be exactly the same as those shown in this manual.

Front Components



| Ref | Component | Description | See Also |
|-----|---|--|----------|
| ❶ | Top Cover Latch | Locks the top cover. | P. 1-4 |
| ❷ | Kensington Lock | Locks the computer to a stationary object for security. | P. 7-3 |
| ❸ | Touchscreen Pen (option) | Provides a convenient way to use the touchscreen. Can be stretched for better grip and handling. | P. 2-12 |
| ❹ | Handle | Allows you to carry your computer for an easy grip. | |
| ❺ | Device Indicators | Show current status of the computer's devices. | |
| |  | AC power indicator Glow green when computer is using AC power. Glow red when the computer, using AC power, is in Sleep mode. | P. 3-2 |

| Ref | Component | Description | See Also |
|-----|---|---|----------|
| |  | <p>Battery Charge Indicator Glow green when the battery is fully charged and connected to AC power. Glow amber when the battery is being charged.</p> | P. 3-3 |
| |  | <p>Battery Power Indicator Glow green when computer is using battery power. Blink amber when the battery is almost completely discharged.</p> | P. 3-3 |
| |  | Combo/DVD Dual drive in-use indicator | P. 2-15 |
| |  | Wireless LAN (Local Area Network) indicator | P. 2-25 |
| |  | Wireless modem indicator | P. 2-28 |
| |  | Wired LAN indicator | P. 2-23 |

Rear Components

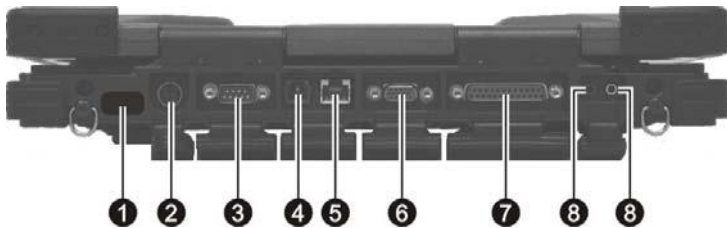

| Ref | Component | Description | See Also |
|-----|------------------------|---|----------|
| ❶ | IR Port | Connects an IrDA-compliant device for wireless data transfer. | P. 4-6 |
| ❷ | Power Connector | Connects the AC adapter. | P. 1-2 |
| ❸ | Serial Port | Connects a serial device, such as an external modem. | P. 4-5 |
| ❹ | RJ-11 Connector | Connects the telephone line. | P. 2-27 |
| ❺ | RJ-45 Connector | Connects the LAN cable. Includes a Link Indicator and an Active Indicator. | P. 2-23 |
| ❻ | VGA Port | Connects an external CRT monitor. | P. 4-2 |
| ❼ | Parallel Port | Connects a parallel device, such as a printer. | P. 4-4 |
| ❽ | Audio Output Connector | Connects a set of headphones, external speakers with amplifier, or an audio recording device. | P. 2-22 |
| ❾ | Microphone Connector | Connects an external microphone. | P. 2-22 |

Right-Side Components

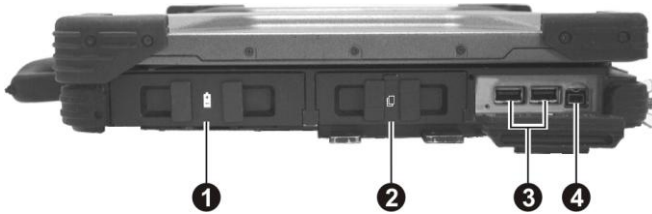

| Ref | Component | Description | See Also |
|-----|-----------------------------|---|----------|
| ① | Primary Battery Pack | Supplies power to your computer when external power is not connected. | P. 3-3 |
| ② | PC Card Slot | Accepts a PC card for additional functions. | P. 4-9 |
| ③ | USB Ports | Each of the two ports connects a USB device, such as a USB floppy drive, USB flash disk, printer, digital camera, joystick, and more. | P. 4-3 |
| ④ | IEEE 1394B Port | Connects a 1394B device such as a mass storage device, digital video (DV) camcorder, or a digital audio device. | P. 4-8 |
| | - or - | | |
| | PS/2 Port | Connects a PS/2 keyboard or mouse. | |

Left-Side Components



| Ref | Component | Description | See Also |
|-----|------------------------------------|--|----------|
| ❶ | Combo / DVD Dual Drive | Accepts a compact disc for installing or loading software, accessing data, and playing music/video. | P. 2-15 |
| | - or - | | |
| ❷ | Secondary Battery Pack | You can purchase a secondary battery pack to be installed here for prolonged battery operating time. | P. 3-6 |
| | Hard Disk Drive Compartment | Contains the hard disk drive of your computer. | P. 2-14 |

Bottom Components





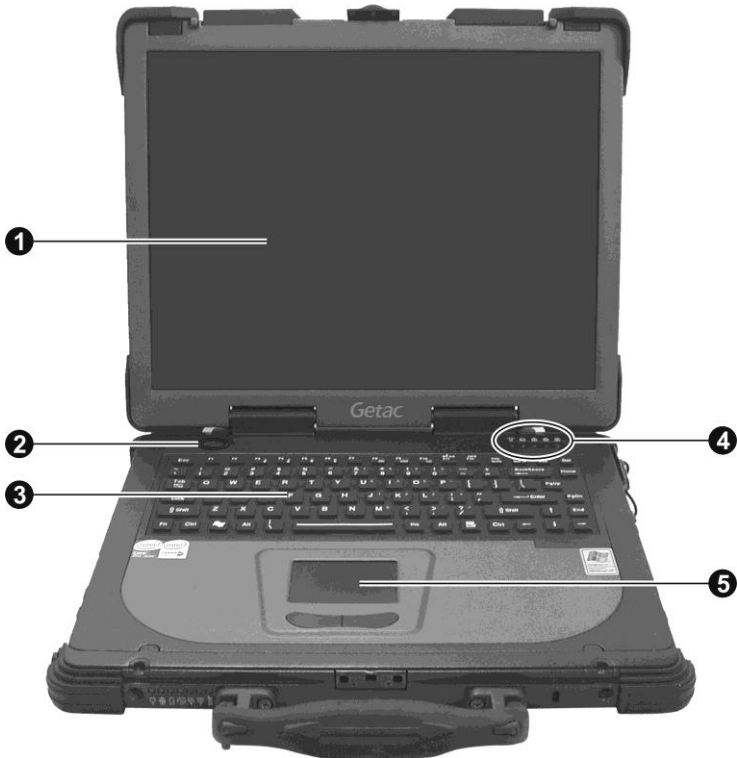

| Ref | Component | Description | See Also |
|----------|---------------------------------|--|-------------------|
| 1 | Stereo Speaker Set | Sends out sound and voice from the computer. | P. 2-21 |
| 2 | Memory Slot | Contains the memory slot for expanding the memory size of your computer. | P. 4-11 |
| 3 | Docking Connector (POGO) | For connecting to a Port Replicator or Car Mount (both are available as an option). | |
| 4 | Release Knob | Allows you to remove the module (optical drive or secondary battery pack) installed in the computer. | P. 2-16 P. 3-6 |

| Ref | Component | Description | See Also |
|-----|---------------------------|---|----------|
| 5 | Docking Antenna Connector | Connects to an external antenna from docking. | |
| 6 | SIM Card Slot | Contains the SIM card slot for using the GSM/ GPRS/CDMA/WCDMA function. | P. 2-28 |

Top-open Components



| Ref | Component | Description | See Also |
|-----|--|---|--------------------|
| ① | Power Button | Turns the computer power ON and OFF. | P. 1-5 |
| ② | Keyboard | Serves as the data input device of the computer. | P. 2-4 |
| ③ | Touchpad | Serves as the pointing device of the computer. | P. 2-9 |
| ④ | Indicators | Show the current status of the computer's devices. | |
| |  | Power indicator – Glow green when the computer is turned ON. Glow amber (orange) when the computer is in Standby/Sleep mode. | P. ?? |
| |  | Hard disk drive in-use indicator Blinks green when the hard disk drive is active. Blinks red when the hard disk heater is on. | P. 2-14 |
| |  | Scroll Lock indicator | P. 2-4 |
| |  | Num Lock indicator | P. 2-5 |
| |  | Caps Lock indicator | P. 2-4 |
| ⑤ | LCD Screen | Displays the output of the computer. Can also have the optional touchscreen function. | P. 2-15 P. 2-12 |

Chapter 2

Operating Your Computer

This chapter provides information about the use of the computer.

If you are new to computers, reading this chapter will help you learn the operating basics. If you are already a computer user, you may choose to read only the parts containing information unique to your computer.

Starting and Stopping the Computer

There are a number of ways to start and stop the computer.

Starting the Computer

You always start the computer using the power button.

A computer starts up with an operating system (OS) existing on the storage device such as the hard disk. The computer will automatically load the OS after you turn it on. This process is called booting.

NOTE: An operating system is the platform for all your software application programs to run on. Your computer uses the Microsoft Windows XP or Vista operating system.

Stopping the Computer

When you finish a working session, you can stop the computer by turning off the power or leaving the computer in Standby/Sleep or Hibernation mode:

| To stop in this mode... | Do this... | To start up or resume again |
|-------------------------|---|-----------------------------|
| Off | Follow the shutdown procedure of your operating system. This can prevent loss of unsaved data or damage to your software programs. If the system is locked up because of hardware or software problems, press the power button to turn off the computer. | Press the power button. |

| To stop in this mode... | Do this... | To start up or resume again |
|-------------------------|--|-----------------------------|
| Standby/Sleep | Depending on your settings in Windows, you can place the computer in Standby/Sleep mode by: <ul style="list-style-type: none"> • Closing the display cover • Pressing the Fn+F12 hot key • Pressing the power button | Press any key. |
| Hibernation | Depending on your settings in Windows, you can place the computer in Hibernation mode by: <ul style="list-style-type: none"> • Closing the display cover • Pressing the Fn+F12 hot key • Pressing the power button | Press the power button. |

If you choose to stop in Standby/Sleep or Hibernation mode, you can return to where you left off the next time you start up the computer. (See “Power Management” in Chapter 3 for more information.)

Using the Keyboard

NOTE: Your computer features backlight for your keyboard to help you see the keyboard keys during poor lighting conditions. Press **Fn+F8** to turn it on/off.

Your special shower-proof and dust-proof rubber keyboard has all the standard functions of a full-sized computer keyboard plus an **Fn** key added for specific functions.

The standard functions of the keyboard can be further divided into four major categories:

- Typewriter keys
- Cursor-control keys
- Numeric keys
- Function keys

Typewriter Keys

Typewriter keys are similar to the keys on a typewriter. Several keys are added such as the **Ctrl**, **Alt**, **Esc**, and lock keys for special purposes. When the lock keys (**Caps Lock** and **Num Lk**) are pressed, their corresponding indicators light up.

The Control (**Ctrl**) / Alternate (**Alt**) key is normally used in combination with other keys for program-specific functions. The Escape (**Esc**) key is usually used for stopping a process. Examples are exiting a program and canceling a command. The function depends on the program you are using.

Cursor-Control Keys



NOTE: The word “cursor” refers to the indicator on the screen that lets you know exactly where on your screen anything you type will appear. It can take the form of a vertical or horizontal line, a block, or one of many other shapes.

Numeric Keypad

A 15-key numeric keypad is embedded in the typewriter keys as shown next:



Numeric keys facilitate entering of numbers and calculations. When Num Lock is on, the numeric keys are activated; meaning you can use these keys to enter numerals.

NOTE:

- When the numeric keypad is activated and you need to type the English letter in the keypad area, you can turn Num Lock off or you can press **Fn** and then the letter without turning Num Lock off.
- Some software may not be able to use the numeric keypad on the computer. If so, use the numeric keypad on an external keyboard instead.

Function Keys

On the top row of the keys are the function keys: **F1** to **F12**. Function keys are multi-purpose keys that perform functions defined by individual programs.

















Fn Key





The **Fn** key, at the lower left corner of the keyboard, is used with another key to perform the alternative function of a key. The letter “Fn” and the alternative functions are identified by the color of blue on the keytop. To perform a desired function, first press and hold **Fn**, then press the other key.

Hot Keys

Hot keys refer to a combination of keys that can be pressed any time to activate special functions of the computer. Most hot keys operate in a cyclic way. Each time a hot key combination is pressed, it shifts the corresponding function to the other or next choice.

You can easily identify the hot keys with the icons imprinted on the keytop. The hot keys are described next.

| Key | Description |
|---|--|
|   | Switches the optional keyboard backlight function on/off with 20 levels of brightness in between. |
|   | Decreases the sound volume. |
|   | Increases the sound volume. |
|   | Decreases the LCD backlight. |
|   | Increases the LCD backlight. |
|   | Switches the LCD on and off. |
|   | <p>Switches the display output to one of the following when an external device is connected.</p> <p>Upon booting the system with CRT:</p> <pre> graph LR CRT --> LCD LCD --> LCD_CRT[LCD & CRT] LCD_CRT --> CRT </pre> <p>NOTE:</p> <ul style="list-style-type: none"> • Fn + F9 will not work when playing a DVD/MPEG movie. • Using the VGA utility's "Graphics Properties" to switch the display output is not allowed. • Display switching when in full screen (maximize view) DOS mode is not allowed. • If the display mode is set to 256 colors or lower, or in DOS mode, there will be only two modes for selecting: CRT only and LCD & CRT. • This function only applies to Plug & Play CRT monitors. |
|   | Serves as the sleep button that you can define with Windows' Power Management . (See "Power Management" in Chapter 3.) |



| Key | Description |
|---|--|
|   | Switches the wireless LAN radio on and off. |
|   | Switches the optional GPS function on and off. |



Euro Symbol

You can press the euro dollar sign € on various keyboards.

- To press the euro sign on a standard United States keyboard, hold down either of the **Alt** keys and type **0128** on the numeric keypad part of your keyboard.
- To press the euro sign on an UK keyboard, hold down the **Alt Gr** key and press **4** (which has an euro sign on it).

Windows Keys

The keyboard has two keys that perform Windows-specific functions:  Windows Logo key and  Application key.

The  Windows Logo key opens the **Start** menu and performs software-specific functions when used in combination with other keys. The  Application key usually has the same effect as a right mouse click. (See your Windows manual for more information.)

Using the Touchpad

CAUTION: Do not use a sharp object such as a pen on the touchpad. Doing so may damage the touchpad surface.

NOTE: For optimal performance of the touchpad, keep your fingers and the pads clean and dry. When tapping on the pad, tap lightly. Do not use excessive force.

The touchpad is a pointing device that allows you to communicate with the computer by controlling the location of the pointer on the screen and making selection with the buttons.



The touchpad consists of a rectangular pad (work surface) and a left and right buttons. To use the touchpad, place your forefinger or thumb on the pad. The rectangular pad acts like a miniature duplicate of your display. As you slide your fingertip across the pad, the pointer (also called cursor) on the screen moves accordingly. When your finger reaches the edge of the pad, simply relocate yourself by lifting the finger and placing it on the other side of the pad.

Here are some common terms that you should know when using the touchpad:

| Term | Action |
|---------------|--|
| Point | Move your finger on the pad until the cursor points to the selection on the screen. |
| Click | Press and release the left button. –or– Tap gently anywhere on the pad. |
| Double-click | Press and release the left button twice in quick succession. –or– Tap twice on the pad rapidly. |
| Drag and drop | Press and hold the left button, then move your finger until you reach your destination (drag). Finally, release the button (drop) when you finish dragging your selection to the destination. The object will drop into the new location. –or– Gently tap twice on the pad and on the second tap, keep your finger in contact with the pad. Then, move your finger across the pad to drag the selected object to your destination. When you lift your finger from the pad, the selected object will drop into place. |
| Scroll | To scroll is to move up and down or left and right in the working area on the screen. To move vertically, place your finger on the right or left edge of the pad and slide your finger up and down along the edge. To move horizontally, place your finger on the top or bottom edge of the pad and slide your finger left and right. |

TABLE NOTE: If you swap the left and right buttons, “tapping” on the touchpad as an alternative method of pressing the left button will no longer be valid.

Configuring the Touchpad

You may want to configure the touchpad to suit your needs. For example, if you are a left-handed user, you can swap the two buttons so that you can use the right button as the left button and vice versa. You can also change the size of the on-screen pointer, the speed of the pointer, and so on.

To configure the touchpad, go to Windows' Control Panel.

Using the Touchscreen (Optional)

NOTE:

- Make sure the **Serial Port COM3 (Touchscreen)** item is set properly in the BIOS Setup program. (See “Advanced Menu” in chapter 5 for information.)
- Make sure the touchscreen driver has been installed properly (see chapter 6 for details).

CAUTION: Do not use a sharp object such as a ballpoint pen or pencil on the touchscreen. Doing so may damage the touchscreen surface. Use your finger or the included touchscreen pen.

The touchscreen is a touch-sensitive device that allows you to easily use the computer without a mouse or touchpad.



Here are some common terms that you should know when using the touchscreen:

| Term | Action |
|---------------|--|
| Click/Point | Tap gently on the touchscreen. |
| Double-click | Tap twice on the touchscreen rapidly. |
| Drag and drop | Press lightly on the touchscreen and move your finger until you reach your destination (drag). Finally, release your finger (drop) when you finish dragging your selection to the destination. The object will drop into the new location. |

Using the Hard Disk Drive

WARNING: DO NOT replace the hard disk drive by yourself. Refer all servicing to qualified personnel or your dealer.

Your computer comes with a removable hard disk drive as drive C. A hard disk drive is a storage device with non-removable, rotating, magnetic storage platters inside it. It is where your operating system and application software programs are stored.

Your hard disk drive is a 2.5-inch hard disk drive. This type of drive embodies the latest in fast, reliable mass storage by integrating all the control circuitry necessary for operation directly onto the drive itself.

The system may come with an optional heater that automatically turns on for low temperature operation. The HDD indicator () blinks red when heater is on.

NOTE: To use the HDD heater feature, the MTCCTRL driver supplied with your computer must be installed (see chapter 6 for details).

CAUTION:

- Make regular backups of your data files from your hard disk drive to USB flash disks or other storage media.
- Never turn off or reset the computer while the hard disk drive in-use indicator is on.

Using the Optical Drive

Depending on the model, your computer comes with a Combo drive or DVD dual recorder located on the left side of the computer. This drive is usually configured as drive D.

Depending on the model, your drive is one of the following:

- **Combo drive** can read CDs, audio CDs, CD-R, CD-RW, and DVD discs, and work as a CD recorder (writing to CD-R/-RW discs).
- **DVD Dual drive** besides the Combo drive function, can write to DVD+R/+RW/-R/-RW discs.

NOTE: If the Combo/DVD Dual drive would be operating for more than half an hour (such as showing a DVD title), use the AC power source instead of the battery. If not, the battery may run out of power before the operation is complete.

CAUTION:

- When inserting a disc, do not use force.
- Make sure the disc is correctly inserted into the tray, and then close the tray.
- Do not leave the DVD tray open. Also, avoid touching the lens in the tray with your hand. If the lens becomes dirty, the disc may malfunction.
- Do not wipe the lens using materials with rough surface (such as paper towel). Instead, use a cotton swab to gently wipe the lens.

FDA regulations require the following statement for all laser-based devices: "Caution, Use of controls or adjustments or performance of procedures other than those specified herein may result in hazardous radiation exposure."

NOTE: The Combo/DVD Dual drive is classified as a Class 1 laser product. This label is located on the drive.

**CLASS 1 LASER PRODUCT
LASER KLASSE 1**

This product incorporates copyright protection technology that is protected by method claims of certain U.S. patents and other intellectual property rights owned by Macrovision Corporation and other rights owners. Use of this copyright protection technology must be authorized by Macrovision Corporation, and is intended for home and other limited viewing uses only unless otherwise authorized by Macrovision Corporation. Reverse engineering or disassembly is prohibited.

Installing the Optical Drive

To install the optical drive:

1. Make sure that the computer is off.
2. Locate the optical drive bay on the left side of the computer.
3. Gently place the computer upside down.
4. Open the optical drive bay cover by pressing on both sides of the release latch using your thumb and index fingers (❶).
5. Lift up the handle of the optical drive release knob and turn it counter-clockwise (❷).



6. If a module (such as secondary battery pack) is inside, pull it out of the bay.

7. Insert the optical drive all the way into the drive bay and close the release knob.



8. Close the optical drive bay cover.

Inserting and Removing a Disc

Follow this procedure to insert or remove a disc.

1. Turn on the computer.
2. Locate the optical drive bay on the left side of the computer.
3. Open the optical drive bay cover by pressing on both sides of the release latch using your thumb and index fingers.



4. Press the eject button and the drive tray will slide out partially. Gently pull on it until it is fully extended.
5. To insert a disc, place down the disc in the tray with its label facing up. Slightly press the center of the disc until it clicks into place.



To remove a disc, hold the disc by its outer edge and lift it up from the tray.

6. Gently push the tray back into the drive.
7. Close the optical drive bay cover.

NOTE: In the unlikely event that you are unable to release the drive tray by pressing the eject button, you can manually release the disc. (See “Optical Drive Problems” in Chapter 8.)

Using the Video Features

The video subsystem of your computer features:

- 14.1-inch TFT (Thin-Film Transistor) color LCD display with XGA (Extended Video Graphics Array) resolution, or 15-inch TFT color LCD display with SXGA+ (Super Extended Video Graphics Array) resolution
- 128 MB shared with system memory
- LCD backlight to help you see the display during poor lighting conditions. Press Fn + F7 to turn it on/off (see Hot Keys in this chapter)
- Simultaneous display on LCD and external monitor, which is useful when you have a presentation as you can control the screen from your computer and face the audience at the same time
- Dual view capability, which allows you to expand your desktop on the screen to another display device so that you have more desktop space to work on
- Power Management
- Touchscreen function (option)
- Sunlight-readable LCD display (option for 14.1-inch LCD)

NOTE:

- To take advantage of the enhanced video capabilities and before using the dual view capability, the VGA driver supplied with your computer must be installed (see chapter 6 for details).
- If you want to use the computer with the LCD closed, make sure the computer is not set to enter the Standby/Sleep or Hibernation mode when the LCD is closed. Use Windows' **Control Panel** → **Power Options** to set up.

Configuring the Display Modes

Your computer has been set to a default resolution and number of colors before shipment. You can view and change display settings through your operating system. See your operating system documentation or online help for specific information.

For displaying in higher resolutions, you can connect an external CRT monitor that supports higher resolutions. (See “Connecting an External Monitor” in Chapter 4 for more information.)

The following table lists the display modes supported by your computer.

| Display Mode | | LCD Only | CRT Only | Simultaneous Display |
|--------------|--------|----------|----------|----------------------|
| Resolution | Colors | | | |
| 1024×768 | 16-bit | √ | √ | √ |
| | 32-bit | √ | √ | √ |
| 1400×1050 | 16-bit | √ | √ | √ |
| | 32-bit | √ | √ | √ |
| 1600×1200 | 16-bit | √ | √ | √ |
| | 32-bit | √ | √ | √ |

TABLE NOTE:

- 16-bit = High Color or 65,536 (64 K) colors; 32-bit = True Color 16,770,000 (16 M) colors.
- When using CRT only, the resolution would depend on the supported resolution by the CRT.

Using the Audio Features

NOTE:

- To take advantage of the enhanced audio capabilities, the audio driver supplied with your computer must be installed. (See chapter 6 for details.)
- If you experience interference while recording, try lowering the microphone recording volume.

The audio subsystem of your computer features:

- External audio connectors (❶)
- A set of speakers (❷)





Ways of playing and recording sound vary with the operating system used. See your operating system documentation or online help for specific information.

Connecting Audio Devices

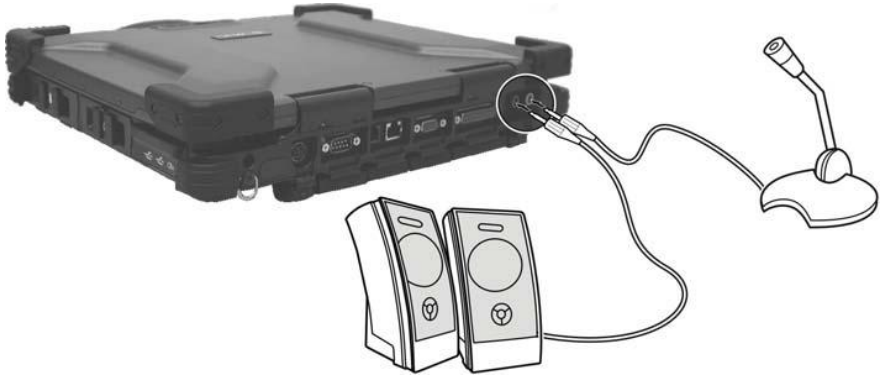
For higher audio quality, you can send or receive sound through external audio devices.



- **Audio Output Connector** () can be connected to the line-in connector of powered speakers with built-in amplifiers, headphones, or earphone set.
- **Microphone Connector** () can be connected to an external microphone for recording voice or sound.

NOTE: When using the external speakers/headphones or microphone, you cannot use the internal one.

Using the Communication Features

Using the LAN

NOTE: To take advantage of the LAN feature, the chipset driver supplied with your computer must be installed. (See chapter 6 for details.)

The internal 10/100/1000Base-T LAN (Local Area Network) module allows you to connect your computer to a network. It supports data transfer rate up to 1000 Mbps.

To connect the network cable to the LAN module, connect one end of the LAN cable to the RJ-45 connector on the computer and the other end to the network hub.



The LAN indicator () glows to indicate that the computer is ready for LAN connection.

Using the Wireless LAN (Optional)

Depending on your model, an internal mini PCI-E wireless LAN (WLAN) card may have been pre-installed by your computer manufacturer at the factory. This card allows you to access corporate networks or the Internet in a wireless environment.

The WLAN features include:

- Peer-to-Peer (Ad-Hoc) and Access Point (Infrastructure) modes support
- WEP (Wired Equivalent Privacy) 64/128-bit data encryption
- IEEE 802.11a/b/g standard compliance

| Technology | 802.11a | 802.11b | 802.11g |
|----------------------------------|---|--|---|
| Stated Maximum Throughput (Mbps) | 54 | 11 | 54 |
| Data Rates (Mbps) | 54, 48, 36, 24, 18, 12, 9, 6 | 11, 5.5, 2, 1 | 54, 36, 18, 9 |
| Band (GHz) | 5.15 ~ 5.35 | 2.412 ~ 2.462 | 2.4 |
| Modulation Technology | OFDM (Orthogonal Frequency Division Multiplexing) | DSSS (Direct Sequence Spread Spectrum) | OFDM (Orthogonal Frequency Division Multiplexing) |

NOTE: 802.11g mode is backward compatible with 802.11b mode.

To take advantage of the WLAN feature, make sure that the WLAN driver is installed correctly (see chapter 6 for details). If your WLAN card was provided by your dealer instead of the computer manufacturer, contact your dealer for the correct driver to use.

Turning Off/On the WLAN Radio

NOTE:

- The FAA (Federal Aviation Agency) has deemed it unsafe to operate wireless devices in aircraft as this may interfere with flight safety. Remember to turn off wireless LAN when using your computer in the airplane.
- The information in this section applies to models with the wireless LAN module only.
- Turning the wireless LAN radio off is not the same as turning off the Windows WLAN utility.

Your computer has a built-in **Fn+F11** WLAN hot key to switch the WLAN on/off. The WLAN indicator () glows to indicate that the computer is ready for WLAN connection.

If you need to temporarily turn off the radio, press **Fn+F11**. To resume network connection, press **Fn+F11** again.

It takes approximately 30 seconds for your computer to make a successful WLAN connection and approximately 10 seconds to disconnect.

Configuring the WLAN

After driver installation, you can use the WLAN utility to configure and monitor your WLAN connection. If you are using Windows Vista, you can also configure WLAN through **Control Panel** → **Network and Internet Connections** → **Network Connections** → **Wireless Network Connection**.

Connecting to a Wireless Network

To connect to a wireless network:

1. Make sure that the WLAN radio is on (controlled by **Fn+F11**).
2. Click **Start** → **All Programs** → **Intel PROSet Wireless** → **Intel PROSet Wireless**.
3. If any wireless network is detected, the following window appears on screen.



4. Click to select a wireless network to connect to, and then click **Connect**.
5. Depending on the settings, you may be asked to enter a wireless security password (encryption key).

For more information on the Intel PROSet Wireless utility, click **Help?** in the **Intel(R) PROSet/Wireless** window.

Using the Modem

NOTE: To take advantage of the modem feature, the modem driver supplied with your computer must be installed (see chapter 6 for details).

The internal 56 K fax/data modem allows you to use the telephone line to communicate with others by fax, email, or connect to an online service or bulletin board.

To connect the telephone line to the modem, connect one end of the modem cable to the RJ-11 connector on the computer and the other end to the phone line.



NOTE:

- When using communication software, you may have to disable power management.
- Set the COM port of the modem to COM3.
- Set parameters such as modem speed (baud rate) and line type (pulse dialing or tone dialing).
- Do not enter Standby/Sleep mode when using communication software.

Using the Wireless Modem (Optional)

Depending on your model, your computer includes an integrated GSM (Global System for Mobile Communications) / GPRS (General Packet Radio Service) feature.

After you establish a subscription with a GSM/GPRS service provider, you can use the wireless data features of your computer. Check with your service provider for a list of available wireless data services. Your service provider may charge additional fees for use of data services.

There are two methods for wirelessly connecting to an ISP or network:

- **GSM data transmission (circuit-switched data)**
GSM data services enable you to use the GSM component of your computer as a built-in modem. You can use the service to connect to the Internet through an ISP or dial in to a corporate network to browse the Web or send and receive e-mail messages.
- **GPRS data transmission**
GPRS is a high-speed data-on service that enables you to transmit data over a mobile network. Subscribing to a GPRS service allows you to transfer files, browse the Web and receive streaming audio and video on your computer.

The wireless modem indicator () glows to indicate that the computer is ready for wireless modem connection.

Connecting Using the GSM Modem

Your computer can send and receive data via a mobile network using the GSM protocol.

To send or receive data over a GSM network, you must have an account with a service provider that supports GSM data services, and the service provider must enable the data features on your account.

To connect to an ISP or dial in to a specific computer, you must configure a connection for that service on your computer.

Connecting Using GPRS

Your computer can receive General Packet Radio Services (GPRS), a high-speed data-only service that transmits data over a mobile telephone network. In addition, GPRS provides permanent on-line connection.

To use GPRS, you must have a subscription to the function with a service provider that supports GPRS.

To connect to a GPRS network, you must configure a connection for that service on your computer.



Using the Bluetooth Feature (Optional)

NOTE: To take advantage of the Bluetooth feature, the Bluetooth driver supplied with your computer must be installed (see chapter 6 for details).

Depending on your model, your computer may incorporate the Bluetooth capability for short-range (about 10 meters) wireless communications between devices without requiring a cable connection.



With Bluetooth, data can be transmitted through walls, pockets and briefcases as long as two devices are within range. By default, your computer's Bluetooth feature is active (always ON) upon booting your computer and is in the general discoverable and pairable mode.

The status of the Bluetooth connection is indicated by the Bluetooth icon located in the system tray in the lower-right part of the screen.

| Status | Icon |
|-----------|---|
| On |  (blue with white logo). |
| Connected |  (blue with green logo) |

You can use the Bluetooth Utility to configure Bluetooth connection settings and transfer files.

Connecting to another Bluetooth Device

1. Make sure that the target Bluetooth device is turned on, discoverable and within close range. (See the documentation that came with the Bluetooth device.)
2. Double-click the  icon, then click **New Connection** or click **Bluetooth**, then **Add New Connection . . .**
Or right-click the  icon, and then click **Add New Connection**.



or



3. The **Add New Connection Wizard** window appears. Select **Express Mode (Recommended)**, then click on **Next**.

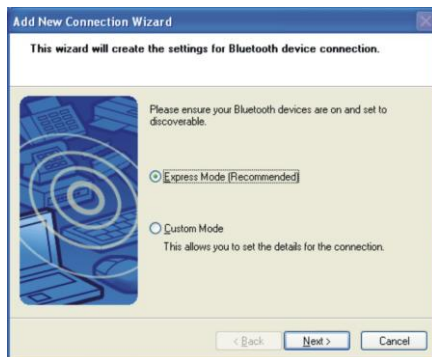

4. Select the device to connect to and click on **Next**.
5. Depending on the type of Bluetooth device that you want to connect to, you will need to enter the pertinent information.

Sending a File

1. Right-click the  icon, and then click **Wireless File Transfer**. The following screen appears.

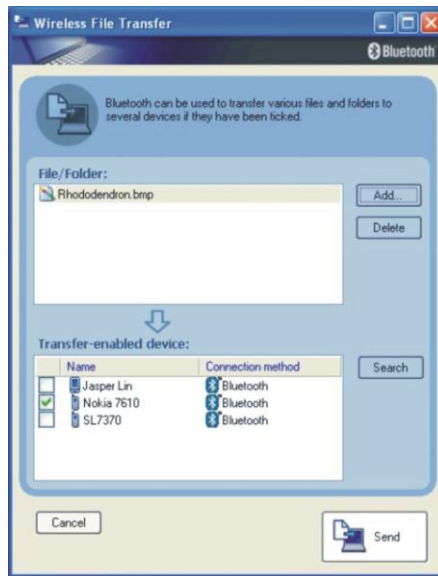

2. In the **Wireless File Transfer** window, click **Add** to browse for the file to send. The file(s) will show on the **File/Folder** window.
3. Click the target device from the **Transfer-enabled device** window, and then click **Send** to start the transfer procedure.

For detailed information on using the Bluetooth Utility, see the Bluetooth Utility Help on your computer by clicking on **Help**, then **Help . . .**

Using the GPS Feature (Optional)

NOTE: To take advantage of the GPS feature, the USB-to-COM driver supplied with your computer must be installed (see chapter 6 for details).

GPS (Global Positioning System) is a constellation of 24 well-spaced satellites that orbit the Earth and make it possible for devices enabled with GPS receivers to pinpoint their location.

You need to install third-party GPS navigation software to take advantage of the GPS feature.

Turning On/Off the GPS

Your computer has a GPS hot key **Fn + F12** to switch the GPS on/off.

Chapter 3

Managing Power

Your computer operates either on external AC power or on internal battery power.

This chapter tells you how you can effectively manage power. To maintain optimal battery performance, it is important that you use the battery in the proper way.

AC Adapter

CAUTION:

- The AC adapter is designed for use with your computer only. Connecting the AC adapter to another device can damage the adapter.
- The AC power cord supplied with your computer is for use in the country where you purchased your computer. If you plan to go overseas with the computer, consult your dealer for the appropriate power cord.
- When you disconnect the AC adapter, disconnect from the electrical outlet first and then from the computer. A reverse procedure may damage the AC adapter or computer.
- When unplugging the connector, always hold the plug head. Never pull on the cord.

The AC adapter serves as a converter from AC (Alternating Current) to DC (Direct Current) power because your computer runs on DC power, but an electrical outlet usually provides AC power. It also charges the battery pack when connected to AC power.

The adapter operates on any voltage in the range of 100~240 V AC.

Battery Pack

The battery pack is the internal power source for the computer. It is rechargeable using the AC adapter.

The operating time of a fully charged battery pack depends on how you are using the computer. When your applications often access peripherals, you will experience a shorter operating time.

NOTE: Additional information on proper use and care for the battery is provided in the “Battery Pack Guidelines” section in Chapter 7.

Charging the Battery Pack

NOTE:

- Charging will not start if the battery’s temperature is below 0 °C (32 °F) or above 60 °C (140 °F).
- The charging process will stop and the Battery Charge Indicator flashes green when the battery’s temperature gets above 60 °C (140 °F). If this happens, the battery pack may be damaged. Please contact your dealer.
- During charging, do not disconnect the AC adapter before the battery has been fully charged; otherwise you will get a prematurely charged battery.

To charge the battery pack, connect the AC adapter to the computer and an electrical outlet. The Battery Charge Indicator () on the computer glows amber to indicate that charging is in progress. You are advised to keep the computer power off while the battery is being charged. When the battery is fully charged, the Battery Charge Indicator glows green.

Depending on the status of the computer, the charging time for the 7200 mAh / 11.1 V battery is:

- 3 hours when the computer is off.
- 6.8 hours when the computer is on and in idle status or when the computer is off but the battery pack’s temperature gets above 45 °C (113 °F).

CAUTION: After the computer has been fully recharged, do not immediately disconnect and reconnect the AC adapter to charge it again. Doing so may damage the battery.

NOTE: The battery level may automatically lessen due to the self-discharge process (0.21 % per day), even when the battery pack is fully charged (100 %). This happens no matter if the battery pack is installed in the computer.

Initializing the Battery Pack

You need to initialize a new battery pack before using it for the first time or when the actual operating time of a battery pack is much less than expected.

Initializing is the process of fully charging, discharging, and then charging. It can take several hours.

1. Make sure the computer power is turned off. Connect the AC adapter to fully charge the battery pack.
2. After the battery pack is fully charged, turn on the computer.
3. Disconnect the AC adapter and leave the computer on until the battery is fully discharged. The computer will shut down automatically.
4. Connect the AC adapter to fully charge the battery pack.

Checking the Battery Level

When two batteries exist on the system, the battery's discharge sequence is from the optional secondary battery (located on the optical drive bay) to the primary battery (located on the right side). When the battery charge on the optional secondary battery falls below 9.1 V, then power usage will switch to the primary battery. When the battery charge on the primary battery falls below 9.1 V, then system will shutdown.

NOTE: Any battery level indication is an estimated result. The actual operating time can be different from the estimated time, depending on how you are using the computer.

You can check the approximate battery level using the battery meter function of the operating system. To read the battery level in Windows, click the battery icon on the system tray.

Replacing the Primary Battery Pack

CAUTION:

- There is danger of explosion if the battery is incorrectly replaced. Replace the battery only with the computer manufacturer's optional battery packs. Discard used batteries according to the dealer's instructions.
- Do not attempt to disassemble the battery pack.

If you often rely on battery power for a long period of time while traveling, you may consider the purchase of an additional battery pack from your dealer and keep it with you in a fully charged state as a backup.

To replace the battery pack, follow these steps:

1. Make sure that the computer is not turned on or connected to AC power.
2. Locate the battery slot on the right side of the system.
3. Open the compartment cover by pressing on both sides of the release latch using your thumb and index fingers.



4. Pull on the ribbon strip to remove the battery pack.



5. Slide the new battery pack all the way into the slot. Make sure to observe the correct orientation (the ribbon strip must face outward for future battery back removal).
6. Close the compartment cover to secure the battery pack.

Installing the Secondary Battery Pack

For prolonged battery operating time, you may consider the purchase of an secondary battery pack from your dealer.

To install the secondary battery pack, follow these steps:

1. Locate the optical drive bay on the left side of the system.
2. Gently place the computer upside down.
3. Open the optical drive bay cover by pressing on both sides of the release latch using your thumb and index fingers (❶).
4. Lift up the handle of the optical drive release knob and turn it counter-clockwise (❷).



5. An existing module such as the optical drive will slide out partially. Gently pull it out of the computer.



6. Slide the secondary battery pack all the way into the bay and close the release knob.
7. Close the cover.

NOTE: The system supports the secondary battery hot-swap function, providing you the ability to replace the battery even during system on. Hot swap means that you can remove and replace without significant interruption to the system (without turning off the system).

Battery Low Signals and Actions

When the battery is low, Windows gives warning messages and the Battery Charge Indicator () blinks amber to alert you. Immediately save your data upon Battery Low. The remaining operating time depends on how you are using the computer. If you are using the audio subsystem, PC card, hard or USB flash disk, the battery might run out of charge very quickly.

NOTE: You can set up the threshold of Battery Low and actions for Windows to take with Windows' **Control Panel** → **Power Options**. (For more information, see Windows' Help.)

Always respond to Battery Low by connecting the AC adapter, turning off the computer, or placing your computer on Hibernation mode.

If you do not take any action, the computer will automatically hibernate (Windows default setting) and turn off.

CAUTION:

- If you are using a PC card, do not access the card during battery low periods. This is because the access may take longer than the time it takes the battery to run out of charge, thus making your access to the card unsuccessful.
- If you fail to save your data when the battery completely runs out of charge, then you lose your data.

Power Management

Your computer supports ACPI (Advanced Configuration and Power Interface) for power management. The power management feature allows you to reduce the power consumption for energy saving.

With an ACPI-compliant operating system such as Windows, power supply to different computer components is controlled on an as-needed basis. This allows maximum power conservation and performance at the same time.

In general, Windows' power management works in this way:

| What... | When... |
|--|--|
| Power to the hard disk is turned off | When the hard disk has been idle for a set period. |
| Power to the display is turned off | When the display has been idle for a set period. |
| The computer enters the Standby or Sleep mode. The hard disk and display are turned off and the entire system consumes less power. | When the entire system has been idle for a set period. |
| | When you press the Fn+F10 hot key. * |
| | When you close the cover. * |
| The computer enters the Hibernation mode. (See the next subsection for more information.) | When you press the Fn+F10 hot key. * |
| | When you close the cover. * |
| | When you press the power button. * |

* Depends on your settings in Windows.

For detailed information on power management, see Windows' Help.

Hibernation Mode

Hibernation is a very useful feature. People frequently open many applications when they use computers. It takes some time to get all these applications open and running, and normally they all have to be closed before the computer can be turned off.

When you use the hibernation feature, you do not have to close the applications. The computer stores the state of your computer to a file on the hard disk and then shuts down. The next time you turn on your computer, you return to exactly where you left off.

Power-Saving Tips

In addition to your computer's automatic power management, you can do your part to maximize the battery's operating time by following these suggestions.

- Do not disable Power Management. Choose a Windows power plan that saves power. A power plan is a collection of hardware and system settings that control how your computer manages power.
- Decrease the LCD brightness to the lowest comfortable level.
- Shorten the length of time before Windows turn off the display.
- Disable the parallel and serial ports if no devices are connected to these ports. (See "Advanced Menu" in Chapter 5.)
- Many USB devices use power just by being connected. If you use a USB mouse, you can save power by disconnecting the mouse and using the touchpad. If you use a USB flash drive, unplug it when you are not using it.
- If you work with an application that uses a PC card, exit the application when you finish using it.
- If you have a PC card installed, remove it when not in use. Some PC cards drain power even while they are inactive.
- If you work with an application that features wireless connectivity (WLAN/modem/GPS/Bluetooth), exit the application when you finish using it (see Chapter 2).
- Turn off the computer when you are not using it.

Chapter 4

Expanding Your Computer

You can expand the capabilities of your computer by connecting other peripheral devices. When using a device, be sure to read the instructions accompanying the device together with the relevant section in this chapter.

Connecting an External Monitor

If you want the benefits of a larger display screen with higher resolution, you can connect an external display monitor to your computer. Follow this procedure to connect an external monitor:

1. Make sure that the computer is not turned on.
2. Plug the monitor's D-type signal connector to the computer's VGA connector.



3. Plug one end of the monitor's power cord into the power socket on the monitor and the other end to an electrical outlet.
4. To use the monitor, turn on the monitor before turning on the computer.
5. The monitor should respond by default. If not, you can switch the display to the monitor or to both (simultaneous display), or to multi-display by pressing the **Fn+F9** hot key. In Windows, you can also change the display through the settings in **Display Properties**.
6. You can change display settings through your operating system. See your operating system documentation or online help for specific information.

CAUTION: Do not disconnect the external monitor while the computer is in the Standby/Sleep mode or Hibernation mode. If no external monitor is connected when the computer resumes, the LCD might not display properly.

Connecting a USB Device

Your computer has two USB ports for connecting USB devices, such as a digital camera, scanner, printer, modem, and mouse.

The USB ports support transfer rates up to 12 MB/s for USB 1.1 devices and 480 MB/s for USB 2.0 devices.

To connect a USB device, simply plug the device cable to one of the USB ports.



Connecting a Parallel Device

Your computer has a parallel port for connecting a parallel device such as a printer. The port supports ECP (Extended Capabilities Port) and EPP (Enhanced Parallel Port) modes that turn the standard parallel port into a high-speed bi-directional peripheral port.

Follow this procedure to connect a parallel device:

1. Make sure that the **Parallel Port** item is set properly in the BIOS Setup program. (See “Advanced Menu” in Chapter 5 for information.)
2. Make sure the computer is not turned on.
3. Plug the parallel device’s cable to the parallel port on the rear of the computer.



4. If the parallel device has independent power, plug its power cord into an electrical outlet.
5. If the parallel device has its own power switch, turn on the device before turning on the computer.

Connecting a Serial Device

Your computer has a serial port for connecting a serial device such as a serial mouse or modem.

Follow this procedure to connect a serial device:

1. Make sure the **Serial Port COM1** item is set properly in the BIOS Setup program. (See “Advanced Menu” in Chapter 5 for information.)
2. Make sure the computer is not turned on
3. Plug the device cable to the serial port on the rear of the computer.



4. Turn on the computer.

NOTE: Portable modems that derive power through the serial port cannot be used with the computer. Instead, use a modem that is powered by its own internal battery or external AC power.

Connecting an IR Device

NOTE:

- Make sure that the IrDA driver is correctly installed (see chapter 6).
- Make sure that the **Serial Port COM2 (FIR)** item is set properly in the BIOS Setup program. (See “Advanced Menu” in Chapter 5 for information.)

Your computer has an IR (infrared) port for connecting an infrared-equipped device wirelessly such as another computer, printer, or PDA (Personal Digital Assistant).

- When using the IR port of your computer to receive data: Place the transmitting device where its IR port faces the IR port of your computer within the effective range – within ± 20 -degrees vertical angle and within ± 20 -degrees horizontal angle at no greater than 0.8~1.0 meter distance.
- When using the IR port of your computer to transmit data: Place the receiving device where the IR port of your computer faces its IR port within the effective range – within ± 15 -degrees vertical angle and within ± 15 -degrees horizontal angle at no greater than 0.8~1.0 meter distance.



To take advantage of the IR communications, you need third party software.

NOTE: During infrared communication, note the following:

- Do not move the computer and IR device.
- Do not enter Sleep mode.
- Do not use a cell phone or another IR device near the computer.
- Avoid strong light such as sunlight or fluorescent light.
- Disable the screensaver.

Connecting an IEEE 1394B Device (Optional)

NOTE: To connect an IEEE 1394A (also known as FireWire 400) device to the computer's IEEE 1394B (also known as FireWire 800) port, you need an optional FireWire 800/FireWire 400 bilingual cable.

Your computer may come with an IEEE 1394B port for connecting IEEE 1394B devices.

IEEE 1394B is the next-generation serial bus standard, featuring high-speed data transfer that doubles the throughput of the original IEEE 1394A interface (from 400 Mbit/sec to 800 Mbit/sec) and dramatically increases the maximum distance of connections (up to 15 feet away, while a FireWire 800 optical repeater will connect devices up to 1000 meters (3300 feet) away). It allows connection of up to 63 devices. The applications include mass storage device, digital video (DV) camcorder, or a digital audio device.

To connect an IEEE 1394B device, prepare an IEEE 1394B cable. Plug the appropriate end of the cable to the computer's IEEE 1394B connector and the other end to the device's corresponding connector.



Using PC Cards

Your computer has a PC card slot that supports the CardBus specifications. Your computer's PC card slot can accommodate a type II card. Typical type II cards are flash memory, SRAM, modem, LAN, and SCSI cards.

Inserting and Removing a PC Card

NOTE:

- Some PC cards require additional system resources. Before using such PC card, you may have to free other system resources for the PC card.
- Although some PC cards can be inserted and removed without turning off the computer, you cannot remove or install PC cards during Standby/Sleep mode.

To insert a PC card:

1. Locate the PC card slot on the right side of the computer.
2. Open the PC card slot cover by pressing on both sides of the release latch using your thumb and index fingers.



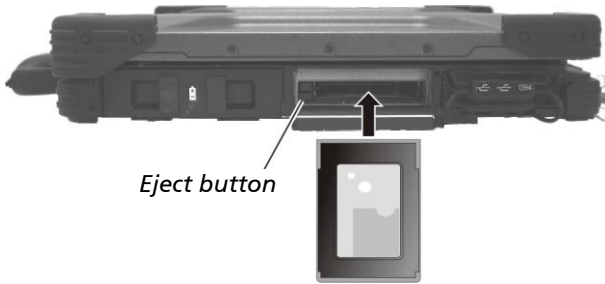

3. Slide the PC card, with its label facing up, into the slot until the eject button pops out.



4. When a new card is seated, the computer will detect it and try to install the appropriate driver. Follow the on-screen instructions to complete the process.

To remove a PC card:

1. Double-click on the **Safely Remove Hardware** icon ( for Windows Vista or  for Windows XP) found on the Windows system tray and the **Safely Remove Hardware** window appears on screen.
2. Select (highlight) the PC card from the list to disable the card.
3. Push the eject button and the card will slide out slightly.
4. Pull the card out of the slot.

System Memory Upgrade

You can upgrade your computer by changing system memory to a maximum of 2 GB on the two 200-pin 533/667 MHz DDR2 SO-DIMM slots.

CAUTION: RAM modules are extremely sensitive to static electricity. There are cases where static electricity generated by the human body has adversely affected such modules. When inserting or removing a RAM module, do not touch the terminals or internal components, insert objects other than the module, or allow foreign particles to enter. Doing so has been known to cause damage, fire, or electrical shock.

To install the RAM module:

1. Remove the battery pack (see chapter 3) and make sure that the computer is not connected to AC power.
2. Carefully place the notebook computer upside down.
3. Remove the nine screws to open the compartment cover.



4. To install the RAM module, match the module's notched part with the socket's projected part and firmly insert the module into the socket at a 20-degree angle. Then push down until the retaining clips lock the module into position.

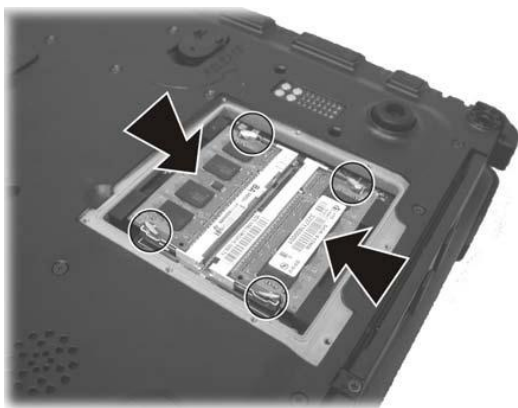

CAUTION: If the RAM module is difficult to insert or difficult to push down, do not force it. Check once more to ensure that the module is positioned correctly.

5. Close the compartment cover and secure with nine screws.

Chapter 5

Using BIOS Setup and System Recovery

BIOS Setup Utility is a program for configuring the BIOS (Basic Input/ Output System) settings of the computer. BIOS is a layer of software, called firmware, that translates instructions from other layers of software into instructions that the computer hardware can understand. The BIOS settings are needed by your computer to identify the types of installed devices and establish special features.

System Recovery reinstalls Windows to your system and configures it to the system's factory default settings.

This chapter tells you how to use the BIOS Setup and System Recovery.

BIOS Setup

When to Use BIOS Setup

When to Use

You need to run BIOS Setup Utility when:

- You see an error message on the screen requesting you to run BIOS Setup Utility.
- You want to restore the factory default BIOS settings.
- You want to modify some specific settings according to the hardware .
- You want to modify some specific settings to optimize the system performance.

Starting BIOS Setup

NOTE:

- The BIOS Setup Utility screens shown in this chapter are for your reference only. The actual items or settings on your computer may differ.
- The BIOS Setup Utility program may have been updated after the publication of this manual.
- The settings you select in your operating system might override similar settings in BIOS Setup Utility.

To run BIOS Setup Utility, press the **F2** key when the prompt appears in the lower left corner of the screen during system startup. The prompt shows up on the screen for only a few seconds. You must press the **F2** key quickly. The BIOS Setup Utility main screen appears as shown next.

| Main | | Advanced | Security | Boot | Exit |
|---|----------------|-------------------------|-------------------|------|--|
| Model: M230N System Time: [16:34:08] System Date: [11/20/2008] ▶ IDE Channel 0 Master [TOSHIBA MK4032GSX-(S1)] ▶ IDE Channel 0 Slave [None] ▶ IDE Secondary/Master [MATSHITA DVD-RAM UJ-850S] ▶ IDE Secondary/Slave [None] System Memory: 640 KB Extended Memory: 3405824 KB System BIOS Version: R1.03 KBC/EC BIOS Version: R1.04b LAN MAC Address: 00-40-D0-C2-6B-B7 | | | | | Item Specific Help <Tab>, <Shift-Tab>, or <Enter> selects field. |
| F1 Help | ↑↓ Select Item | -/+ Change Values | F9 Setup Defaults | | |
| Esc Exit | ←→ Select Menu | Enter Select ▶ Sub-Menu | F10 Save and Exit | | |

The BIOS Setup Utility screen can be divided into four areas:

- On the top is the menu bar containing the titles of the available menus. Each menu title brings a specific menu.
- The left column of the menu displays the menu items.
- The right column of the menu provides more detailed information when a menu item is highlighted.
- The bottom of the menu provides keyboard instructions for moving around and making selections.

Moving Around and Making Selections

You must go through two or three levels to complete the setting for an item. In most cases, there are two levels: menu title and submenu.

Use the keyboard to move around and make selections. Keyboard information can be found at the bottom of the screen. A brief description of keyboard usage is listed next:

| Key | Function |
|-------|---|
| ←, → | Selects a menu title. |
| ↑, ↓ | Selects an item or option. |
| + / - | Changes the value. |
| Enter | 1) Brings up the sub-menu when available. 2) Opens or closes the option window when an item is selected. |
| Esc | 1) Exits BIOS Setup Utility. 2) Closes the option window if one is open. |
| F1 | Provides help information. |
| F9 | Loads setup defaults. |
| F10 | Saves and exit the BIOS Setup Utility. |

Main Menu

The Main menu contains the system date and time settings as well as shows the basic configuration of the system.

| Main | Advanced | Security | Boot | Exit |
|--|----------------------------------|-----------------------------------|------------|--|
| Model: M230N System Time: [16:34:08] System Date: [11/20/2008] | | | | Item Specific Help |
| ▶ IDE Channel 0 Master [TOSHIBA MK4032GSX-(S1)] ▶ IDE Channel 0 Slave [None] ▶ IDE Secondary/Master [MATSHITA DVD-RAM UJ-850S] ▶ IDE Secondary/Slave [None] | | | | <Tab>, <Shift-Tab>, or <Enter> selects field. |
| System Memory: 640 KB Extended Memory: 3405824 KB | | | | |
| System BIOS Version: R1.03 KBC/EC BIOS Version: R1.04b | | | | |
| LAN MAC Address: 00-40-D0-C2-6B-B7 | | | | |
| F1 Help Esc Exit | ↑↓ Select Item ←→ Select Menu | -/+ Change Values Enter Select | ▶ Sub-Menu | F9 Setup Defaults F10 Save and Exit |

System Time sets the system time.

System Date sets the system date.

IDE Channel 0 / Secondary Master/Slave sets the type of storage device installed.

Advanced Menu

The Advanced menu contains the I/O (input/output) configuration settings of the system.

| Main | Advanced | Security | Boot | Exit |
|--|----------------|-------------------|-------------------|--|
| Serial Port COM1: [Enabled] | | | | Item Specific Help The COM1 Port. Enabled = COM1 will be enabled. Disabled = COM1 will be unconditionally disabled. |
| Serial Port COM2 (FIR): [Enabled] | | | | |
| Serial Port COM3 (Touchscreen): [Enabled] | | | | |
| Serial Port COM4 (XBay): [Enabled] | | | | |
| Parallel Port: [Enabled] | | | | |
| Mode: [ECP] | | | | |
| SATA – Device 31, Function 2: [Compatible] | | | | |
| Boot-time Diagnostic Screen: [Disabled] | | | | |
| F1 Help | ↑↓ Select Item | -/+ Change Values | F9 Setup Defaults | |
| Esc Exit | ←→ Select Menu | Enter Select | ▶ Sub-Menu | F10 Save and Exit |

Serial Port COM1 enables or disables the serial (COM1) port. The options are *Enabled* and *Disabled*.

Serial Port COM2 (FIR) enables or disables the infrared (COM2) port. The options are *Enabled* and *Disabled*.

Serial Port COM3 (Touchscreen) enables or disables the touchscreen (COM3) function. The options are *Enabled* and *Disabled*.

Serial Port COM4 (XBay) enables or disables the XBay (COM4) port. The options are *Enabled* and *Disabled*.

Parallel Port enables or disables the parallel port. The options are *Enabled* and *Disabled*.

Mode sets the mode for the parallel port. The options are *Output only*, *Bi-directional*, *ECP*, and *EPP*.

SATA – Device 31, Function 2 sets the primary/secondary compatible/enhanced SATA/PATA (serial ATA / parallel ATA) controller in Legacy/Native mode. The options are *Compatible* and *Enhanced*.

AHCI Configuration allows you to enable the enhanced AHCI function (Windows XP Service Pack 1 + IAA driver supports AHCI mode). This item only appears if the previous item **SATA – Device 31, Function 2** is set at *Enhanced*. The options are *Enabled* and *Disabled*.

Boot-time Diagnostic Screen sets if the system diagnostic screen would be displayed during system boot-up. The options are *Enabled* and *Disabled*.

Security Menu

The Security menu contains the TPM (Trusted Platform Module) setting. TPM is a component on your computer's motherboard that is specifically designed to enhance platform security above-and-beyond the capabilities of today's software by providing a protected space for key operations and other security critical tasks. Using both hardware and software, the TPM protects encryption and signature keys at their most vulnerable stages – operations when the keys are being used unencrypted in plain-text form. The TPM is specifically designed to shield unencrypted keys and platform authentication information from software-based attacks.

- TPM acts as a portal to an unlimited amount of protected data.
 - Supports encrypted file systems, etc.
 - What types of data are protected? Small data (< 2048 bits)
 - Symmetric encryption/decryption keys
 - Signing keys
 - How is data protected? Encrypted by asymmetric RSA keys
 - TPM checks integrity of decrypted data
 - Decrypted data may only be released when TPM is in an approved state
- Object Types:
 - Storage Root Key (SRK) protects all TPM protected objects
 - Storage keys protect (decrypt) child nodes
 - Signature keys are always at the leaf of the tree
 - Data blobs are always at the leaf of the tree
- Object Access:
 - Access time depends on position in the tree
 - Object caching is supported during a boot cycle

- TPM is shipped without an owner installed.
 - Ownership configured to be taken remotely or locally
 - Owner may be: User of the system (consumer PC)
 - IT department (corporate PC) owner authorizes privileged operations
 - Creating keys, making identities, key migration
- Proves integrity of a command. Authenticates entity(s) associated with a command
 - Owner, key, data blob, etc.
 - Authorization secret is shared secret between entity and TPM
 - 20 bytes of data
 - HMAC-SHA1 key prevent commands from being replayed

| Main | Advanced | Security | Boot | Exit |
|-------------------------|----------------|-------------------------|--------------------|------|
| Supervisor Password is: | | Clear | Item Specific Help | |
| User Password is: | | Clear | | |
| Set Supervisor Password | | [Enter] | | |
| Set User Password | | [Enter] | | |
| Fixed disk boot sector: | | [Normal] | | |
| Password on boot: | | [Disabled] | | |
| TPM Support | | [Disabled] | | |
| F1 Help | ↑↓ Select Item | -/+ Change Values | F9 Setup Defaults | |
| Esc Exit | ←→ Select Menu | Enter Select ► Sub-Menu | F10 Save and Exit | |

Supervisor/User Password Is shows whether you have set the supervisor/user password or not for the system.

Set Supervisor/User Password sets the supervisor/user password. When typing the password, first make sure that Num Lock is off, and then type the password in the entry fields and press **Enter**. Confirm your password by typing it again and pressing **Enter**. You can set the supervisor/user password to be required for starting up the system and/or entering BIOS Setup.

NOTE:

- You can set the user password only when the supervisor password has been set.

- If both the administrator and user passwords are set, you can enter any of them for starting up the system and/or entering BIOS Setup. However, the user password only allows you to view/change the settings of certain items.

Fixed disk boot sector allows you to set if a warning message will appear when the hard disk boot sector (partition table) has been changed.

CAUTION: Set this item to disabled before installing an Operating System, running `Fdisk` or `Format` program. Otherwise, the intended action will fail.

Password on Boot allows you to enable or disable the entering of password for booting up your system. Once the password is successfully set and this item is enabled, it is required for booting up the system.

TPM Support enables or disables TPM support. Upon selecting *Enabled*, the following screen appears. The options are *Enabled* and *Disabled*.

NOTE: To use the TPM feature, the TPM driver supplied with your computer must be installed (see chapter 6 for details).

Boot Menu

The Boot menu sets the sequence of the devices to be searched for the operating system.

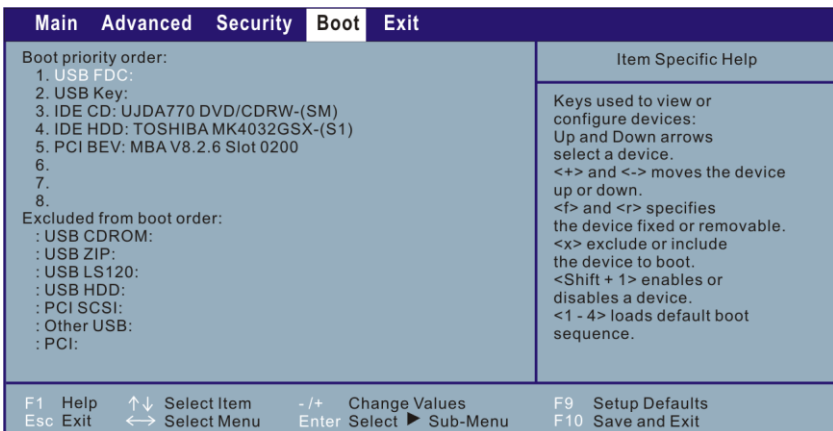

The bootable devices will be automatically detected during POST and shown here, allowing you to set the sequence that the BIOS uses to look for a device from which to load the OS.

Below is a brief description of keyboard usage:

| Key | Function |
|---------|--|
| ↑, ↓ | Selects (highlight) a boot device. |
| +, - | Changes the boot sequence. |
| 1 to 4 | Loads the default boot sequence. |
| f or r | Specifies if the device is fixed (f) or removable (r). |
| X | Moves the highlighted boot device from the "Boot priority order" list to the "Excluded from boot order" list, and vice versa. |
| Shift+1 | Deactivates/activates the highlighted boot device on the "Boot priority order" list. When a device has been deactivated, an "!" (exclamation) symbol appears beside the item and system will bypass it when detecting boot device during POST. |

Exit Menu

The Exit menu displays ways of exiting BIOS Setup Utility. After finishing with your settings, you must save and exit so that the changes can take effect.

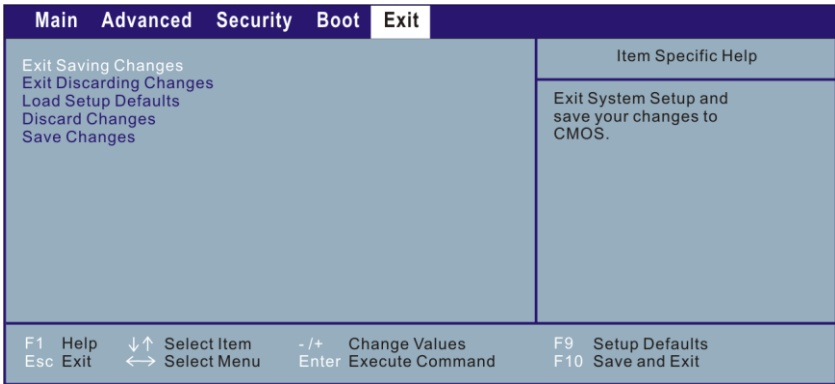

Exit Saving Changes saves the changes you have made and exits BIOS Setup Utility.

Exit Discarding Changes exits BIOS Setup Utility without saving the changes you have made.

Load Setup Defaults loads the factory default values for all the items.

Discard Changes restores the previous values for all the items.

Saves Changes saves the changes you have made.

System Recovery

You need to run System Recovery when:

- Your computer does not start correctly.
- Your Windows operating system does not start at all.
- You want to restore the factory default Windows settings.

WARNING: Using this feature will reinstall Windows to your system and configure it to the system's factory default settings. All data on the hard disk drive will be lost.

To run System Recovery:

1. During system startup when the following screen appears, press **Ctrl + Alt + F2** keys for four seconds.

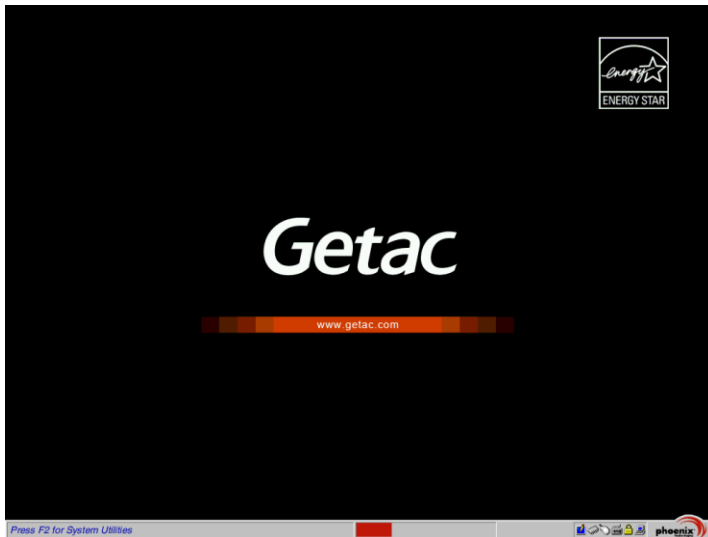

2. The message "This will help you reinstall Windows to the whole HDD to factory default. All data on HDD will be lost" appears on the screen to ask

if you want to access System Recovery. Type 1 to continue or type 0 to exit.

3. A warning message appears as follows:

You must accept the following terms before performing the recovery process:
1. The recovery software is solely the purpose of reinstalling or restoring software associated with the hard disk of this operating GETAC machine.
2. Except the above, no other use is granted hereunder.

(1) Yes, I agree to the provisions of this agreement and wish to continue.
(0) No, I do not agree to the provisions of this agreement and do not wish to continue.

Type 1 to continue.

4. Type Y when the message "Are you sure you want to recover now? (Y)Yes (N)No" appears onscreen. The following screen appears and system will perform the recovery process and Windows operating system will be re-installed to its default setting.

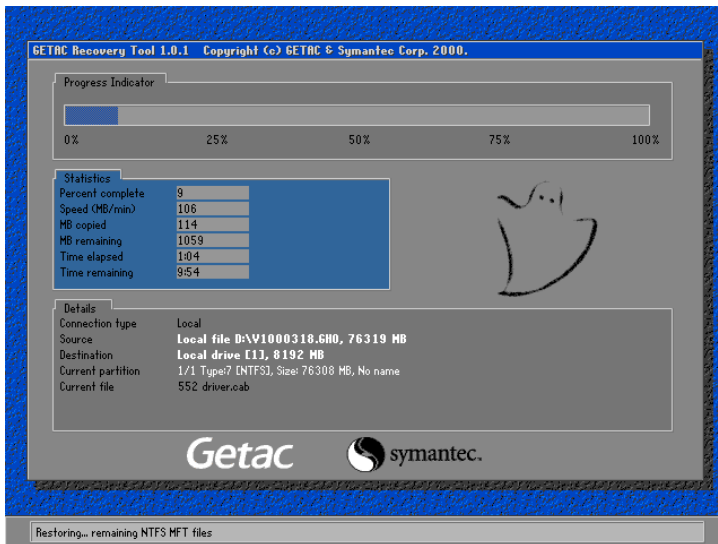

5. After the recovery process has been completed successfully, the GSI (GETAC Smart Installer) screen is displayed at the first boot-up of Windows operating system.

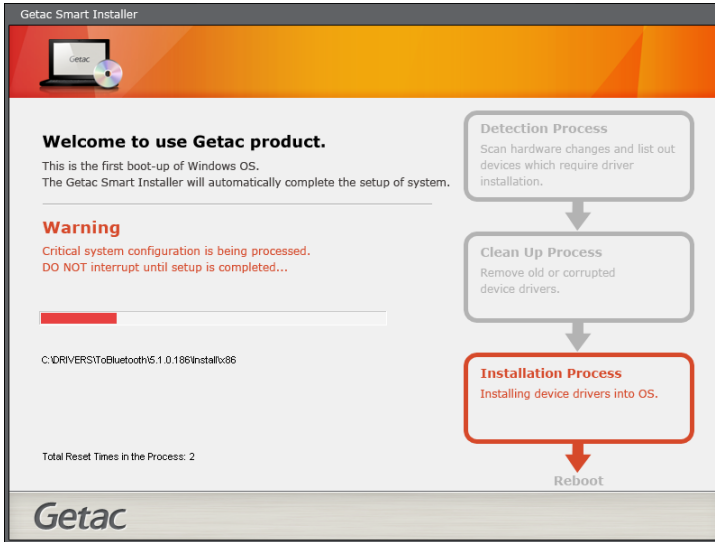

6. GSI will automatically perform system hardware detection and driver installation. After GSI has completed the whole process successfully, system will reboot.

Chapter 6

Installing Software Drivers and Utilities

To take full advantage of the unique features of your computer, drivers and utilities must be installed.

If you purchased the computer with Windows pre-installed, your dealer may have already installed the drivers and utilities. If not, you need to install them using the disc supplied with your computer.

This chapter describes how to install the drivers and utilities.

How to Use the Driver Disc

NOTE:

- The drivers may have been updated after this manual was published. For driver upgrade, please contact your dealer.
- This disc supports Windows XP and Windows Vista.
- The available items may differ according to your computer model.
- Do not remove the driver disc when installing the driver.

An autorun program is provided on the driver disc to help you easily install the drivers. As you insert the disc, the autorun program automatically starts. If you need to start the program manually, run the `Autorun.exe` program from the driver disc.

When the following screen appears select **Windows XP** or **Windows Vista** based on the operating system installed.



The **User Guide** item on the screen allows you to view the User Manual with Adobe Acrobat Reader. If you do not have Adobe Acrobat Reader on your computer, install the program by clicking **Adobe Reader**.

Installation for Windows XP

After selecting the operating system **Windows XP** from the main screen, the driver installation screen appears as shown next:



To install a driver, just click the particular button and follow the onscreen instructions to continue and complete installation.

Drivers on the First Page

Device Driver Ensures the full function of the following drivers. Install this main driver before installing the other drivers. Upon clicking this button, the chipset, VGA, audio, modem, and LAN drivers would be installed one after the other.

Nvidia Installs the optional Nvidia VGA controller driver.

NOTE: You need to install the Nvidia driver if your system comes with the Nvidia VGA controller and if you are using Windows XP Service Pack 2 only.

- PROSet** Installs the WLAN driver that allows your system to connect wirelessly to the Internet.
- Hotfix** Allows you to install the Microsoft hotfix (for Windows XP Service Pack 2 only).
- TouchScreen** Allows you to use your fingers as a pointing device on the LCD screen. (See “Touchscreen Utility” for further instructions).
- TPM** Upon clicking this button, the following screen appears.



CAUTION: Before installing the TPM driver, make sure the **TPM Support** item under the **Security** menu in the BIOS SETUP is set to *Enabled*. (See “Security Menu” in Chapter 5 for information.)

| | | |
|--------------------|--------------------|---|
| | Driver | Allows you to install the driver for using the TPM (Trusted Platform Module) support for security. |
| | Application | Allows you to install the TPM application. |
| TouchScreen | | Allows you to use your fingers (or optional touchscreen pen) as a pointing device on the LCD screen (refer to the next section for further instructions). |

Drivers on the Second Page

Upon clicking on **Next Page** from page 1, the following screen appears.



Vehicle Dock Upon clicking on this, the following screen appears.



Video Capture Allows you to install the video capture driver (STK1120/STK1160) to connect a video capture device through the AV input port (option).

USB-to-COM Allows you to use the optional wireless modem and GPS features to transmit information wirelessly.

MTCCTRL Allows you to use the built-in heater feature that automatically turns on for low temperature hard disk drive operation.

OSD Installs the OSD (on screen display) utility that provides a graphic display to indicate the current status of certain operations.

Option Driver Upon clicking on this, the following screen appears.



- Optional Hotfix** Upon clicking on this, the following screen appears. The items on this screen allow you to install the hotfix for using USB, WCDMA, and Bluetooth devices.
- WCDMA** Allows you to install the Novatel EU740 / Sierra 8775V WCDMA driver and application.
- CDMA** Allows you to install the Sierra 5720/25V CDMA driver and application.
- Bluetooth** Allows you to install the Bluetooth driver and application program for using the Bluetooth feature.
- Smart Card** Allows you to install the smart card driver for using the smart card reader feature.

Module Switch Allows you to power ON/OFF the Bluetooth® wireless feature / WLAN radio as well as set the power ON/OFF state during system startup.

Battery Calibration Upon clicking on this, the following screen appears.

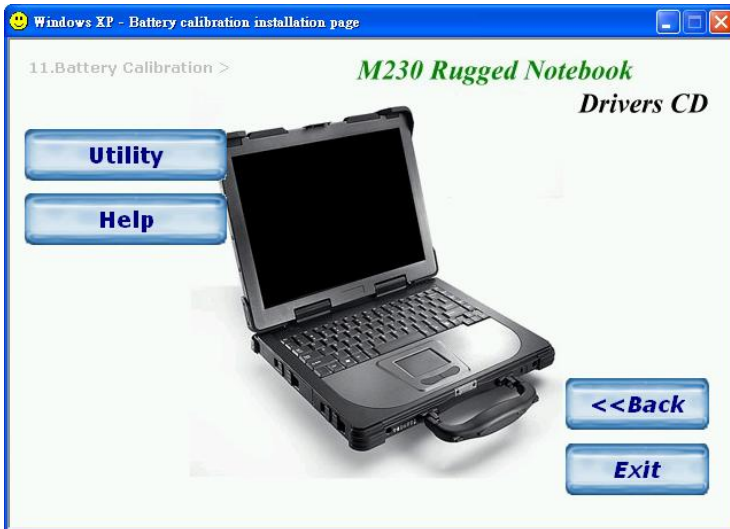

Utility Installs the battery pack automatic calibration utility that includes the Battery Monitor and Battery Learning programs.

Help Displays the instructions for performing a battery calibration.

NOTE: For Windows 2000 only. Install the DirectX 8.1 driver to take full advantage of multimedia applications. Run the file **DX81NTeng.exe** located on the **/Utility/DirectX/** directory on your driver disc.

Installation for Windows Vista

After selecting the operating system **Windows Vista** from the main screen, the driver installation screen appears as shown next:

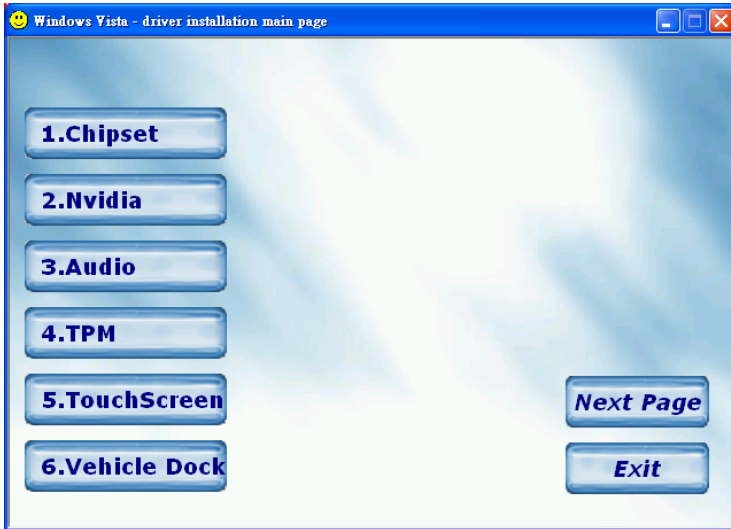

To install a driver, just click the particular button and follow the onscreen instructions to continue and complete installation.

Drivers on the First Page

- | | |
|----------------|---|
| Chipset | Ensures the full function of the following drivers. Install this main driver before installing the other drivers. Upon clicking this button, the chipset, VGA, modem, and LAN drivers would be installed one after the other. |
| Nvidia | Installs the optional Nvidia VGA controller driver. |

NOTE: You need to install the Nvidia driver if your system comes with the Nvidia VGA controller only.

- Audio** Installs the audio driver that allows you to take full advantage of the audio subsystem.
- TPM** Upon clicking on this, the following screen appears.



CAUTION: Before installing the TPM driver, make sure the **TPM Support** item under the **Security** menu in the BIOS SETUP is set to *Enabled*. (See “Security Menu” in Chapter 5 for information.)

- Driver** Allows you to install the driver for using the TPM (Trusted Platform Module) support for security.
- Application** Allows you to install the TPM application.
- TouchScreen** Allows you to use your finger (or optional touchscreen pen) as a pointing device on the LCD screen. (See “Touchscreen Utility” for further instructions).

Vehicle Dock Upon clicking on this, the following screen appears:



Video Capture Allows you to install the video capture driver (STK1160) to connect a video capture device through the AV input port (option).

USB-to-COM Allows you to use the wireless modem and GPS features to transmit information wirelessly.

Drivers on the Second Page

Upon clicking on **Next Page** from page 1, the following screen appears.



- | | |
|----------------|--|
| IrDA | Installs the IR driver that allows you to use the infrared function of the computer. |
| MTCCTRL | Allows you to use the built-in heater feature that automatically turns on for low temperature hard disk drive operation. |
| OSD | Installs the OSD (on screen display) utility that provides a graphic display to indicate the current status of certain operations. |

Option Driver Upon clicking on this, the following screen appears.

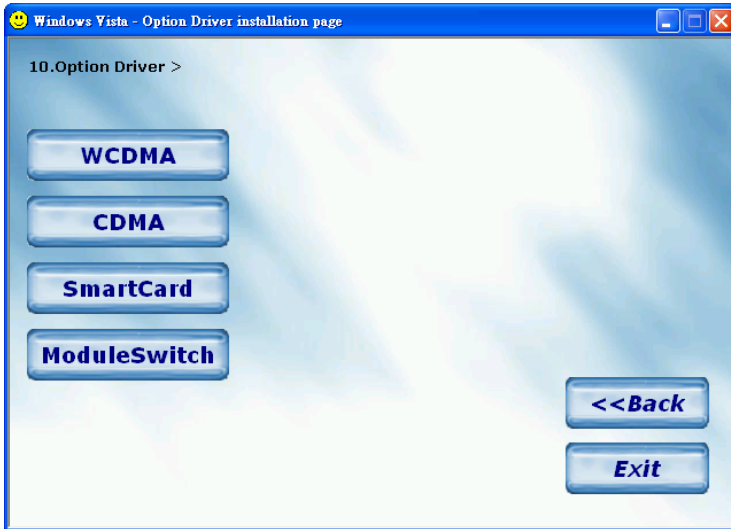

- | | |
|----------------------|---|
| WCDMA | Installs the Novatel EU740 / Sierra 8775V WCDMA driver and application. |
| CDMA | Install the Sierra 5720/25V CDMA driver and application. |
| Smart Card | Installs the smart card driver for using the smart card reader feature. |
| Module Switch | Allows you to power ON/OFF the <i>Bluetooth</i> [®] wireless feature / WLAN radio as well as set the power ON/OFF state during system startup. |

Battery Calibration

Upon clicking this button, the following screen appears.



Utility

Installs the battery pack automatic calibration utility that includes the Battery Monitor and Battery Learning programs.

Help

Displays the instructions for performing a battery calibration.

Using Special Utilities

Touchscreen Utility

After installing the touchscreen driver/utility, you can use **PenMount Monitor** to configure your touchscreen.

1. Click the **PenMount Monitor** icon  located on the system tray bring up the **PenMount Control Panel**.
2. Click **Standard Calibration**.

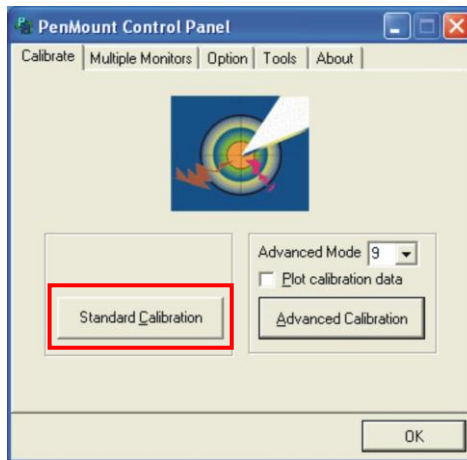













3. Click on the four sides (points) and the plus-sign "+" on the screen to calibrate your touchscreen for use on the computer.

OSD for Hot Key Operations

With the OSD driver installed, it is activated every time Windows starts up.

A graphic display will appear on the screen to indicate the current status when you perform a hot key operation (as listed next). The OSD disappears after a few seconds.

| Icon Hot Key/Button Operation | | OSD Description | |
|---|--|--|--|
|  Fn+F3 |  Fn+F4 | Icon appears on the screen whenever you adjust Windows or any of its application program's volume control (e.g., Windows Media Player, etc.) to indicate the volume level. The OSD disappears after a few seconds. | |
|  Fn+F5 |  Fn+F6 | Icon appears on the screen to indicate the brightness level. The OSD disappears after a few seconds. | |
|  Fn+F7/F8 On |  Fn+F7/F8 Off | Icon appears on the screen to indicate that LCD backlight (Fn+F7) or display (Fn+F8) is on or off. The OSD disappears after a few seconds. | |
|  Fn+F9 LCD |  Fn+F9 CRT |  Fn+F9 Both | Icon appears on the screen to indicate the current display output. The OSD disappears after a few seconds. |
|  Fn+F11 On |  Fn+F11 Off | Icon appears on the screen whenever you press Fn + F11 to indicate that wireless LAN is on or off. The OSD disappears after a few seconds. | |

| Icon Hot Key/Button Operation | | OSD Description |
|---|---|--|
|  |  | Icon appears on the screen to indicate that AC power cord has been connected or unplugged. The OSD disappears after a few seconds. |

Chapter 7

Caring for the Computer

Taking good care of your computer will ensure a trouble-free operation and reduce the risk of damage to your computer.

This chapter gives you guidelines covering areas such as protecting, storing, cleaning, and traveling.

Protecting the Computer

To safeguard the integrity of your computer data as well as the computer itself, you can protect the computer in several ways as described in this section.

Using an Anti-Virus Strategy

You can install a virus-detecting program to monitor potential viruses that could damage your files.

Using the Windows Security Center (Windows Vista only)

Windows Security Center alerts you to take action on the following security essentials:

- Windows Firewall
- Windows Update
- Malware Protection (anti-virus, anti-spyware)
- Others (Internet security, user account control)

For detailed information on Windows Security Center, see Windows' Help.

Using the Password

The power-on password protects your computer against unauthorized use. If the password is set, the prompt requesting for the password appears on the screen whenever the computer is turned on.

The password is set via the BIOS Setup program. See "Security Menu" in Chapter 5 for instructions.

Using the Cable Lock

You can use a Kensington-type cable lock to protect your computer against theft. The cable lock is available in most computer stores.

To use the lock, loop the lock cable around a stationary object such as a table. Insert the lock to the Kensington lock hole and turn the key to secure the lock. Store the key in a safe place.

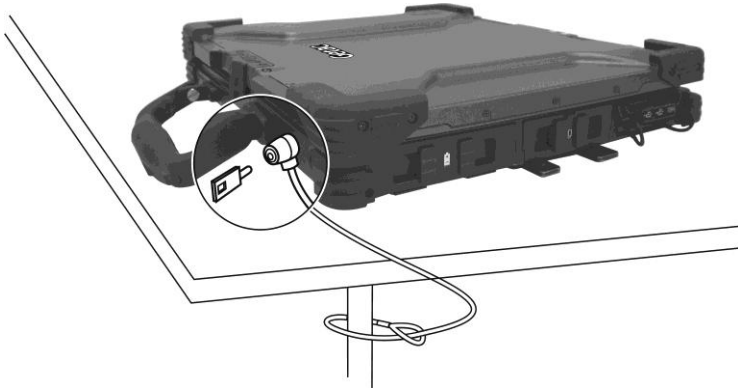

Taking Care of the Computer

Location Guidelines

- For optimal performance, use the computer where the recommended temperature is between 0 °C (32 °F) and 55 °C (131 °F) – actual operating temperature depending on product specifications.
- Avoid placing the computer in a location subject to high humidity, extreme temperatures, mechanical vibration, direct sunlight, or heavy dust.
- Do not cover or block any ventilation openings on the computer. For example, do not place the computer on a bed, sofa, rug, or other similar surface. Otherwise, overheating may occur that results in damage to the computer.
- Keep the computer at least 13 cm (5 inches) away from electrical appliances that can generate a strong magnetic field such as a TV, refrigerator, motor, or a large audio speaker.
- Avoid moving the computer abruptly from a cold to a warm place. A temperature difference of more than 10 °C (18 °F) may cause condensation inside the unit, which may damage the storage media.
- Do not place the computer on an unsteady surface.

General Guidelines

- Do not place heavy objects on top of the computer when it is closed as this may damage the display.
- The screen surface is easily scratched. Do not use paper towels to clean the display but use the included soft cloth. Avoid touching it with your fingers, pen, or pencil.
- To maximize the life of the backlight in the display, allow the backlight to automatically turn off as a result of power management. Avoid using

a screen saver or other software that prevents the power management from working.

Cleaning Guidelines

- Never clean the computer with its power on.
- Use a soft cloth moistened with water or a non-alkaline detergent to wipe the exterior of the computer.
- Gently wipe the display with a soft, lint-free cloth. Do not use alcohol or detergent on the display.
- Dust or grease on the touchpad can affect its sensitivity. Clean the pad by using adhesive tape to remove the dust and grease on its surface.

Battery Pack Guidelines

- Recharge the battery pack when it is nearly discharged. When recharging, make sure that the battery pack is fully charged. Doing so may avoid harm to the battery pack.
- The battery pack is a consumable product and the following conditions will shorten its life:
 - when frequently charging the battery pack
 - when using, charging, or storing the battery in high temperature condition
- To avoid hastening the deterioration of the battery pack thereby prolonging its useful life, minimize the number of times you charge it so as not to frequently increase its internal temperature.
- Charge the battery pack between 10 °C ~ 30 °C (50 °F ~ 86 °F) temperature range.
A higher environment temperature will cause the battery pack's temperature to rise. Avoid charging the battery pack inside a closed vehicle and in hot weather condition.
Also, charging will not start if the battery pack is not within the allowed temperature range.

- It is recommended that you do not charge the battery pack more than once a day.
- It is recommended that you charge the battery pack with the computer's power off.
- To maintain the battery pack's operating efficiency, store it in a cool dark place removed from the computer and with 30 % ~ 40 % charge remaining.
- Important guidelines when using the battery pack.

When installing or removing the battery pack take note of the following:

- avoid installing or removing the battery pack when the computer is in Sleep mode. Abruptly removing the battery pack may cause loss of data or the computer may become unstable.
- avoid touching the battery pack terminals or damage may occur, thereby causing improper operation to it or the computer.

The computer's input voltage and surrounding temperature will directly affect the battery pack's charge and discharge time:

- charging time will be prolonged when the computer is turned on. To shorten the charging time, it is recommended that you place the computer in sleep or hibernation mode.
- a low temperature will prolong the charging time as well as hasten the discharge time.

Touchscreen Guidelines

- Use the finger or the included touchscreen pen on the display. Using a sharp or metallic object other than your finger or touchscreen pen may cause scratches and damage the display, thereby causing errors.
- Avoid using excessive force that may cause damage to the display.
- Use a soft cloth to remove dirt on the display. The touchscreen surface has a special protective coating that prevents dirt from sticking to it. Not using a soft cloth may cause damage to the special protective coating on the touchscreen surface.

To remove hard to remove dirt, blow some steam on the particular area and gently wipe away using a soft cloth.

- Turn off the computer power when cleaning the display. Cleaning the display with the power on may cause improper operation.
- Use the touchscreen within the intended area only. The display area and touchscreen operating area is the same. Using it beyond the allowed area may cause damage to the display and result in improper operation.
- Do not use excessive force on the display. Avoid moving the computer while holding the display or twisting the display. Avoid placing objects on top of the display as this may cause the glass to break thereby damaging the display.
- Using the touchscreen during low temperature (less than 5 °C) may cause a slower response time, this is normal. A normal response time may be restored upon returning to room temperature.
- When there is noticeable discrepancy in the operation of the touchscreen function (wrong location on intended operation or improper display resolution), refer to the Windows online Help for instructions on recalibrating the touchscreen display.

When Traveling

- Before traveling with your computer, make a backup of your hard disk data into flash disks or other storage devices. As an added precaution, bring along an extra copy of your important data.
- Make sure that the battery pack is fully charged.
- Make sure that the computer is turned off and the top cover is securely closed.
- Do not leave objects in between the keyboard and closed display.
- Disconnect the AC adapter from the computer and take it with you. Use the AC adapter as the power source and as a battery-charger.
- Hand-carry the computer. Do not check it in as luggage.
- If you need to leave the computer in the car, put it in the trunk of the car to avoid exposing the computer to excessive heat.
- When going through airport security, it is recommended that you send the computer and flash disks through the X-ray machine (the device you set your bags on). Avoid the magnetic detector (the device you walk through) or the magnetic wand (the handheld device used by security personnel).
- If you plan to travel abroad with your computer, consult your dealer for the appropriate AC power cord for use in your country of destination.

Chapter 8

Troubleshooting

Computer problems can be caused by hardware, software, or both. When you encounter any problem, it might be a typical problem that can easily be solved.

This chapter tells you what actions to take when solving common computer problems.

Preliminary Checklist

Here are helpful hints to follow before you take further actions when you encounter any problem:

- Try to isolate which part of the computer is causing the problem.
- Make sure that you turn on all peripheral devices before turning on the computer.
- If an external device has a problem, make sure that the cable connections are correct and secure.
- Make sure that the configuration information is properly set in the BIOS Setup program.
- Make sure that all the device drivers are correctly installed.
- Make notes of your observations. Are there any messages on the screen? Do any indicators light? Do you hear any beeps? Detailed descriptions are useful to the service personnel when you need to consult one for assistance.

If any problem persists after you follow the instructions in this chapter, contact an authorized dealer for help.

Solving Common Problems

Battery Problems

The battery does not charge (Battery Charge indicator does not light yellow).

- Make sure that the AC adapter is properly connected.
- Make sure that the battery is not too hot or cold. Allow time for the battery pack to return to room temperature.
- Make sure that the battery pack is installed correctly.
- Make sure that the battery terminals are clean.

The operating time of a fully charged battery becomes shorter.

- If you often partially recharge and discharge, the battery might not be charged to its full potential. Initialize the battery to solve the problem. (See “Initializing the Battery Pack” in Chapter 3 for instructions.)

The battery operating time indicated by the battery meter does not match the actual operating time.

- The actual operating time can be different from the estimated time, depending on how you are using the computer. If the actual operating time is much less than the estimated time, initialize the battery. (See “Initializing the Battery Pack” in Chapter 3 for instructions.)

Bluetooth Problems

I cannot connect to another Bluetooth-enabled device.

- Make sure that the Bluetooth driver is correctly installed.
- Make sure that both devices have activated Bluetooth.
- Make sure that the distance between the two devices are not over 10 meters or that there are no walls or other obstructions between the devices.

- Make sure that the other device is not in “Hidden” mode.
- Make sure that both devices are compatible.

I cannot end a Bluetooth connection.

- If another device is connected to your computer, you can either end the connection using the other device or by deactivating Bluetooth.

Display Problems

Nothing appears on the screen.

- If the power-on indicator is not on, check the electrical outlet, the plugs and power cords.
- If the power button does not respond to a light touch, press the button firmly.
- If you are using battery power, make sure that it has a charge remaining and that it is installed correctly.
- During operation, the screen may automatically turn off as a result of power management. Press any key to see if the screen comes back.
- The brightness level might be too low. Increase brightness by pressing the **Fn+F6** hot key.
- The display output might be set to an external device. To switch the display back to the LCD, press the **Fn+F9** hot key or change the display through the settings in **Display Properties**.
- Try turning the computer off, wait for a few seconds, then turn it back on.

The characters on the screen are dim.

- Adjust the brightness and/or contrast.

Bad dots appear on the display at all times.

- A small number of missing, discolored, or bright dots on the screen are an intrinsic characteristic of TFT LCD technology. It is not regarded as a LCD defect.

Resolution cannot be adjusted to desired setting.

- Make sure that the VGA driver is installed correctly.

The external monitor displays nothing.

- Make sure that the monitor is turned on.
- Make sure that the monitor's signal cable is properly connected.
- Switch the display to the monitor by pressing the **Fn+F9** hot key or change the display through the settings in **Display Properties**.

Simultaneous display/multi-display does not work.

- Make sure that you turn on the external monitor before turning on the computer.
- Press the **Fn+F9** hot key to toggle through the display options or change the settings in **Display Properties** in Windows.

Hardware Device Problems

The computer does not recognize a newly installed device.

- The device may not be correctly configured in the BIOS Setup program. Run the BIOS Setup program to identify the new type.
- Make sure if any device driver needs to be installed. (Refer to the documentation that came with the device.)
- Make sure if the device needs any jumper or switch settings. (Refer to the documentation that came with the device.)
- Check the cables or power cords for correct connections.
- For an external device that has its own power switch, make sure that the power is turned on.

Hard Disk Drive Problems

The hard disk drive error message appears on the screen.

- The hard disk drive has defects. Ask your dealer for help.

The hard disk drive operations seem slow.

- The data files stored on the hard disk drive may be fragmented. Use a tool such as Window's **Disk Defragmenter** to defragment the files.

The hard disk drive in-use indicator glows without blinking.

- The data files stored on the hard disk drive may be fragmented. Use a tool such as Window's **Disk Defragmenter** to defragment the files.

Infrared Problems

The IR port does not work.

- Make sure that the IR ports of the two device face each other within a \pm 15-degrees angle and 1 meter (3 feet) distance and there are no obstructions in between.
- Make sure that the device connected is using an equivalent speed.
- If you are printing to an infrared printer, make sure that the appropriate driver is installed.
- Make sure that the IrDA Fast Infrared Port is set to HP HSDL-2300/3600.
- Make sure that the IR port is set correctly in the BIOS Setup program.
- If you are printing to an infrared printer, make sure that the appropriate driver is installed.
- If you are using any file transfer functions, make sure that both the computer and the IR device have the appropriate software running.
- Make sure that there is no device radiating infrared rays, such as remote-controlled devices or wireless headphones, near the computer or device.
- Make sure that no direct sunlight or fluorescent lamps are near the computer or device.
- Make sure that the IR ports are clean.

Keyboard, Mouse, and Touchpad Problems

The keyboard does not respond.

- Try connecting an external keyboard. If it works, contact an authorized dealer, as the internal keyboard cable might be loose.

The numeric keypad is disabled.

- Make sure that the **Num Lock** is switched on. (Check if the Num Lock Indicator  glows or not.)

The external keyboard does not work.

- Make sure that the keyboard cable is properly connected.

The USB mouse does not work.

- Make sure that the mouse cable is properly connected.

The touchpad does not work, or the pointer is difficult to control with the touchpad.

- Make sure that the touchpad is clean.

LAN Problems

I cannot access the network.

- Make sure that the LAN driver is correctly installed.
- Make sure that the LAN cable is properly connected to the RJ-45 connector and the network hub.
- Make sure that the network configuration is appropriate.
- Make sure that the user name or password is correct.

WLAN Problems

I cannot use the WLAN feature.

- Make sure that the necessary driver(s) is correctly installed.

- Make sure that the WLAN feature is turned on (Fn+F11).

Transmission quality is poor.

- Your computer may be in an out-of-range situation. Move your computer closer to the Access Point or another WLAN device it is associated with.
- Check if there is high interference around the environment and solve the problem as described next.

Radio interference exists.

- Move your computer away from the device causing the radio interference such as microwave oven and large metal objects.
- Plug your computer into an outlet on a different branch circuit from that used by the affecting device.
- Consult your dealer or an experienced radio technician for help.

I cannot connect to another WLAN device.

- Make sure that the WLAN feature is turned on (Fn+F11).
- Make sure that the SSID setting is the same for every WLAN device in the network.
- Your computer is not recognizing changes. Restart the computer.
- Make sure that the IP address or subnet mask setting is correct.

I cannot communicate with the computer in the network when Infrastructure mode is configured.

- Make sure that the Access Point your computer is associated with is powered on and all the LEDs are working properly.
- If the operating radio channel is in poor quality, change the Access Point and all the wireless station(s) within the BSSID to another radio channel.
- Your computer may be in an out-of-range situation. Move your computer closer to the Access Point it is associated with.
- Make sure that your computer is configured with the same security option (encryption) to the Access Point.

- Use the Web Manager/Telnet of the Access Point to check whether it is connected to the network.
- Reconfigure and reset the Access Point.

I cannot access the network.

- Make sure that the necessary driver(s) is correctly installed.
- Make sure that the network configuration is appropriate.
- Make sure that the user name or password is correct.
- You have moved out of range of the network.
- Turn off power management.

Modem Problems

The modem does not work.

- Make sure that the modem driver is correctly installed.
- Make sure that the telephone line is properly connected.
- Make sure that the COM port in the communication software is correctly set.
- Turn off power management.

Optical Drive Problems

The optical drive cannot read a disc.

- Make sure that the disc is correctly seated in the tray, with the label facing up.
- Make sure that the disc is not dirty. Clean the disc with a disc cleaning kit, available in most computer stores.
- Make sure that the optical drive driver is installed correctly.
- Make sure that the computer supports the disc or the files contained.

You cannot eject a disc.

- The disc is not properly seated in the drive. Manually release the disc following the method described next:
 1. Turn off the system.
 2. Insert a small rod, such as a straightened paperclip, into the drive's manual eject hole and push firmly to release the tray.
 3. Pull the tray out until fully extended, and then remove the disc.



PC Card Problems

The PC card does not work.

- Make sure that the PC card is correctly seated.
- If the card requires an IRQ (Interrupt ReQuest), make sure that there is one available. Or you can release another device IRQ in the BIOS Setup program.

The PC card stops communicating properly.

- The application may have been reset when the computer is turned off or in Standby/Sleep mode. Exit and restart the application.

Power Management Problems

The computer does not enter Standby/Sleep or Hibernation mode automatically.

- If you have a connection to another computer, the computer does not enter Standby/Sleep or Hibernation mode if the connection is actively in use.
- Make sure that the Standby/Sleep or Hibernation time-out is enabled.

The computer does not enter Standby/Sleep or Hibernation mode immediately.

- If the computer is performing an operation, it normally waits for the operation to finish.

The computer does not resume from Standby/Sleep or Hibernation mode.

- The computer automatically enters Standby/Sleep or Hibernation mode when the battery pack is empty. Do any one of the following:
 - Connect the AC adapter to the computer.
 - Replace the empty battery pack with a fully charged one.

The computer does not enter Hibernation mode with the Fn+F10 hot keys.

- Make sure that the Hibernation function is specified for the sleep button.

Printer Problems

The printer does not work.

- Make sure that the printer is turned on (if it comes with an independent power source) and is online (ready to use).
- Make sure that the printer's signal cable is properly connected.
- Make sure that the printer driver is correctly installed.

- Make sure that you have assigned the printer port correctly in your operating system or application program.
- Make sure that the printer port is enabled in the BIOS SETUP program.

The printer prints garbled information.

- Make sure that the printer driver is correctly installed.
- Make sure that the printer cable is properly connected.

Software Problems

An application program does not work correctly.

- Make sure that the software is correctly installed.
- If an error message appears on the screen, consult the software program's documentation for further information.
- If you are sure the operation has stop, reset the computer. (See "Resetting the Computer" later in this chapter.)

Sound Problems

No sound is produced.

- Make sure that the volume control is not set too low.
- Make sure that the audio driver is correctly installed.
- Make sure that the computer is not in Standby/Sleep mode.
- If using an external speaker, make sure that the speaker is properly connected.

Distorted sound is produced.

- Make sure that the volume control is not set too high or too low. In most cases, a high setting can cause the audio electronics to distort the sound.

The sound system does not record.

- Adjust the playback or recording sound levels.

The external microphone or audio device does not work.

- Make sure that the microphone is connected to the proper connector on the computer.
- Make sure that your computer is equipped with the driver needed.
- Click the speaker symbol on the taskbar and check the Windows volume control.
- Check the volume control of your computer.

Startup Problems

When you turn on the computer, it does not respond and the Power Indicator does not light green.

- If you are using an external AC power, make sure that the AC adapter is correctly and securely connected. If so, make sure that the electrical outlet works properly.
- If you are using the battery power, make sure that the battery is not discharged.

When you turn on the computer, it stops after POST.

- Restart your computer.

Other Problems

The date/time is incorrect.

- Correct the date and time via the operating system or BIOS Setup program.
- After you have performed everything as described above and still have the incorrect date and time every time you turn on the computer, the RTC (Real-Time Clock) battery is at the end of its life. Call an authorized dealer to replace the RTC battery.

Resetting the Computer

You may have to reset (reboot) your computer on some occasions when an error occurs and the program you are using hangs up.

If the computer operation seems to hang up, first wait. It is possible that the computer is processing data. Periodically check the hard disk drive in-use indicator, if it flashes irregularly, the program may be accessing data and preventing you from using the keyboard. If you are sure the operation has stopped and you cannot use the “restart” function of the operating system, reset the computer.

Reset the computer by any one of these methods:

- Press **Ctrl+Alt+Del** on your built-in keyboard.
- If the above action does not work, turn off the computer with the power button. Wait for at least five seconds and turn it on again.

CAUTION: Resetting will cause any unsaved data to be lost.

Appendix A

Specifications

NOTE: Specifications are subject to change without any prior notice.

| Parts | | Specifications |
|-----------------|------------------------|---|
| CPU | | Intel® core duo LV processor, 1.66 GHz |
| Core logic | | Intel® 945GMS chipset + ICH7-M |
| RAM | System | 512 MB DDR2 |
| | Video | 128 MB (shared system memory) |
| Display | Panel | 14.1/15-inch TFT XGA/SXGA LCD Touchscreen (option), sunlight-readable (option) Touchscreen + sunlight-readable (option) |
| | Video controller | Integrated in Intel® 945GM chipset Discrete ATi M54 (option) |
| | Video port | VGA port |
| Keyboard | | Sealed membrane cover, rubber with backlight feature |
| Pointing device | | Standard capacitance touchpad |
| Storage device | Hard disk drive | Easily removable for maintenance, optional built-in heater for low temperature support |
| | Optical drive (option) | Easily swappable bay for slim-type Combo/DVD dual drive |
| Audio | Ports | Two audio ports for Mic-in / Line-out |
| I/O ports | On right side | X-Bay, two USB ports (supports system boot-up from optical drive), IEEE 1394B or PS/2 port (option) |
| | On rear side | IR port, serial port, RJ-11 port, RJ-45 port, parallel port |
| | On underside | Docking port (POGO) supports hot docking |
| Communications | LAN | 10/100/1000Base-T Ethernet with TPM security function |
| | Wireless LAN | Intel® Pro/Wireless 3945 a/b/g with built-in antenna |
| | Wireless WAN | HSDPA – option |
| Bluetooth | | Bluetooth 2.0 module with built-in antenna – option |
| GPS | | GPS module with built-in antenna – option |

| Parts | | Specifications |
|-------------------|-------------------|---|
| Power | AC adapter | Input: 100~240 V AC, 50~60 Hz universal adapter |
| | Primary Battery | Li-ion 9-cell 7800 mAh / 11.1 V |
| | Secondary Battery | Li-ion 3700 mAh / 11.1 V – option via optical drive bay |
| Dimension (WxDxH) | | 12.9×10.7×1.81 inch (328×272.1×46 mm) for 14.1-inch model 13.3×11.25×1.81 inch (338×286×46 mm) for 15-inch model |
| Weight | | Less than 9.25 lb (4.2 kg) for 14.1-inch model Less than 9.7 lb (4.4 kg) for 15-inch model |
| Environment | Temperature | Operating: –20 °C (–4 °F) to 55 °C (131 °F) |

Appendix B

Regulatory Information

This appendix provides regulatory statements and safety notices on your computer.

NOTE: Marking labels located on the exterior of your computer indicate the regulations that your model complies with. Please check the marking labels and refer to the corresponding statements in this appendix. Some notices apply to specific models only.

On the Use of the System

Class B Regulations

USA

Federal Communications Commission Radio Frequency Interference Statement

NOTE:

This equipment has been tested and found to comply with the limits for a Class B digital device pursuant to Part 15 of the FCC Rules. These limits are designed to provide reasonable protection against harmful interference in a residential installation. This equipment generates, uses, and can radiate radio frequency energy and, if not installed and used in accordance with the instructions, may cause harmful interference to radio communications. However, there is no guarantee that interference will not occur in a particular installation. If this equipment does cause harmful interference to radio or television reception, which can be determined by turning the equipment off and on, the user is encouraged to try to correct the interference by one or more of the following measures:

- Reorient or relocate the receiving antenna.
- Increase the separation between the equipment and receiver.
- Connect the equipment into an outlet on a circuit different from that to which the receiver is connected.
- Consult the dealer or an experienced radio/TV technician for help.

Any changes or modifications not expressly approved by the manufacturer could void the user's authority to operate the equipment.

Please note:

The use of a non-shielded interface cable with this equipment is prohibited.

Canada

Canadian Department of Communications Radio Interference Regulations Class B Compliance Notice

This Class B digital apparatus meets all requirements of the Canada Interference-Causing equipment regulations.

Cet appareil numérique de Classe B respecte toutes les exigences du Règlement Canadien sur le matériel brouilleur.

This digital apparatus does not exceed the Class B limits for radio noise emissions from digital apparatus set out in the Radio Interference Regulations of the Canadian Department of Communications.

Le présent appareil numérique n'émet pas de bruits radioélectriques dépassant les limites applicables aux appareils numériques de la classe B prescrites dans le Règlement sur le brouillage radioélectrique édicté par le ministère des Communications du Canada.

Safety Notices

About the Battery

Caution Texts Concerning Lithium Batteries

DANISH

ADVARSEL! Lithiumbatteri – Eksplosionsfare ved fejlagtig håndtering. Udskiftning må kun ske med batteri af samme fabrikat og type. Levér det brugte batteri tilbage til leverandøren.

NORWEGIAN

ADVARSEL: Eksplosjonsfare ved feilaktig skifte av batteri. Benytt samme batteritype eller en tilsvarende type anbefalt av apparatfabrikanten. Brukte batterier kasseres i henhold til fabrikantens instruksjoner.

SWEDISH

WARNING: Explosionsfara vid felaktigt batteribyte. Använd samma batterityp eller en ekvivalent typ som rekommenderas av apparattillverkaren. Kassera använt batteri enligt fabrikantens instruktion.

FINNISH

VAROITUS: Paristo voi räjähtää, jos se on virheellisesti asennettu. Vaihda paristo ainoastaan valmistajan suosittelemaan tyyppiin. Hävitä käytetty paristo valmistajan ohjeiden mukaisesti.

ENGLISH

CAUTION: Danger of explosion if battery is incorrectly replaced. Replace only with the same or equivalent type recommended by the equipment manufacturer. Discard used batteries according to manufacturer's instructions.

DEUTSCH

VORSICHT: Explosionsgefahr bei unsachgemäßem Austausch der Batterie. Ersatz nur durch denselben oder einen vom Hersteller empfohlenen gleich-wertigen Typ. Entsorgung gebrauchter Batterien nach Angaben des Herstellers.

FRENCH

ATTENTION: Il y a danger d'explosion s'il y a un remplacement incorrect de la batterie. Remplacer uniquement avec une batterie du même type ou d'un type équivalent recommandé par le constructeur. Mettre au rebut les batteries usagées conformément aux instructions du fabricant.

Attention (for USA Users)

The product that you have purchased contains a rechargeable battery. The battery is recyclable. At the end of its useful life, under various state and local laws, it may be illegal to dispose of this battery into the municipal waste stream. Check with your local solid waste officials for details in your area for recycling options or proper disposal.

About the AC Adapter

- Use only the AC adapter supplied with your computer. Use of another type of AC adapter will result in malfunction and/or danger.
- Do not use the adapter in a high moisture environment. Never touch the adapter when your hands or feet are wet.
- Allow adequate ventilation around the adapter when using it to operate the device or charge the battery. Do not cover the AC adapter with

paper or other objects that will reduce cooling. Do not use the AC adapter while it is inside a carrying case.

- Connect the adapter to a proper power source. The voltage requirements are found on the product case and/or packaging.
- Do not use the adapter if the cord becomes damaged.
- Do not attempt to service the unit. There are no serviceable parts inside. Replace the unit if it is damaged or exposed to excess moisture.

About the Modem

Caution

- Never install telephone wiring during a lightning storm.
- Never install telephone jacks in wet locations unless the jack is specifically designed for wet locations.
- Never touch non-insulated telephone wires or terminals unless the telephone line has been disconnected at the network interface.
- Use caution when installing or modifying telephone lines.
- Avoid using the telephone function (other than a cordless type) during an electrical storm. There may be a remote risk of electric shock from lightning.
- Do not use the telephone function to report a gas leak in the vicinity of the leak.
- Do not use this product near water, for example near a bathtub, wash bowl, kitchen sink or laundry tub, in a wet basement or near a swimming pool.

Caution (for USA Users)

To reduce the risk of fire, use only No.26 AWG or larger telecommunication line cord.

On the Use of the RF Device

NOTE: The information in this section applies to models with the wireless LAN module.

USA and Canada Safety Requirements and Notices

IMPORTANT NOTE: To comply with FCC RF exposure compliance requirements, the antenna used for this transmitter must be installed to provide a separation distance of at least 20 cm from all persons and must not be co-located or operating in conjunction with any other antenna or transmitter.

Radio Frequency Interference Requirements and SAR

The FCC with its action in ET Docket 93-62 has adopted a safety standard for human exposure to Radio Frequency (RF) electromagnetic energy emitted by FCC certified equipment. The wireless LAN module meets the Human Exposure limits found in OET Bulletin 65, 2001, and ANSI/IEEE C95.1, 1992. Proper operation of this radio according to the instructions found in this manual will result in exposure substantially below the FCC's recommended limits. The following safety precautions should be observed:

- Do not touch or move antenna while the unit is transmitting or receiving.
- Do not hold any component containing the radio such that the antenna is very close or touching any exposed parts of the body, especially the face or eyes, while transmitting.
- Do not operate the radio or attempt to transmit data unless the antenna is connected; if not, the radio may be damaged.

Use in specific environments:

- The use of wireless devices in hazardous locations is limited by the constraints posed by the safety directors of such environments.

- The use of wireless devices on airplanes is governed by the Federal Aviation Administration (FAA).
- The use of wireless devices in hospitals is restricted to the limits set forth by each hospital.

Antenna use:

- In order to comply with FCC RF exposure limits, low gain integrated antennas should be located at a minimum distance of 20 cm (8 inches) or more from the body of all persons.
- High-gain, wall-mount, or mast-mount antennas are designed to be professionally installed and should be located at a minimum distance of 30 cm (12 inches) or more from the body of all persons. Please contact your professional installer, VAR, or antenna manufacturer for proper installation requirements.

Explosive Device Proximity Warning

WARNING: Do not operate a portable transmitter (such as a wireless network device) near unshielded blasting caps or in an explosive environment unless the device has been modified to be qualified for such use.

Antenna Warning

WARNING: To comply with the FCC and ANSI C95.1 RF exposure limits, it is recommended that the antenna for this device be installed so as to provide a separation distance of at least 20 cm (8 inches) from all persons and that the antenna must not be co-located or operating in conjunction with any other antenna or radio transmitter. It is recommended that the user limit exposure time if the antenna is positioned closer than 20 cm (8 inches).

Use on Aircraft Caution

CAUTION: Regulations of the FCC and FAA prohibit airborne operation of radio-frequency wireless devices because their signals could interfere with critical aircraft instruments.

EMC Requirements

This device uses, generates and radiates radio frequency energy. The radio frequency energy produced by this device is well below the maximum exposure allowed by the Federal Communications Commission (FCC).

This device complies with the limits for a Class B digital device pursuant to Part 15 subpart C of the FCC Rules and Regulations. Operation is subject to the following two conditions:

- (1) This device may not cause harmful interference.
- (2) This device must accept any interference received, including interference that may cause undesired operation.

The FCC limits are designed to provide reasonable protection against harmful interference when the equipment is installed and used in accordance with the instruction manual and operated in a commercial environment. However, there is no guarantee that interference will not occur in a particular commercial installation, or if operated in a residential area.

If harmful interference with radio or television reception occurs when the device is turned on, the user must correct the situation at the user's own expense. The user is encouraged to try one or more of the following corrective measures:

- Reorient or relocate the receiving antenna.
- Increase the separation between the equipment and receiver.
- Connect the equipment into an outlet on a circuit different from that to which the receiver is connected.
- Consult the dealer or an experienced radio/TV technician for help.

CAUTION: The Part 15 radio device operates on a non-interference basis with other devices operating at this frequency. Any changes or modification to said product not expressly approved by the manufacturer could void the user's authority to operate this device.

Canada Radio Frequency Interference Requirements

To prevent radio interference to the licensed service, this device is intended to be operated indoors and away from windows to provide maximum

shielding. Equipment (or its transmit antenna) that is installed outdoors is subject to licensing.

Pour empêcher que cet appareil cause du brouillage au service faisant l'objet d'une licence, il doit être utilisé à l'intérieur et devrait être placé loin des fenêtres afin de fournir un écran de blindage maximal. Si le matériel (ou son antenne d'émission) est installé à l'extérieur, il doit faire l'objet d'une licence.

European Union CE Marking and Compliance Notices

Statements of Compliance

English

This product follows the provisions of the European Directive 1999/5/EC.

Danish

Dette produkt er i overensstemmelse med det europæiske direktiv 1999/5/EC.

Dutch

Dit product is in navolging van de bepalingen van Europees Directief 1999/5/EC.

Finnish

Tämä tuote noudattaa EU-direktiivin 1999/5/EC määräyksiä.

French

Ce produit est conforme aux exigences de la Directive Européenne 1999/5/EC.

German

Dieses Produkt entspricht den Bestimmungen der Europäischen Richtlinie 1999/5/EC.

Greek

Το προϊόν αυτό πληροί τις προβλέψεις της Ευρωπαϊκής Οδηγίας 1999/5/EC.

Icelandic

Pessi vara stenst reglugerð Evrópska Efnahags Bandalagsins númer 1999/5/EC.

Italian

Questo prodotto è conforme alla Direttiva Europea 1999/5/EC.

Norwegian

Dette produktet er i henhold til bestemmelsene i det europeiske direktivet 1999/5/EC.

Portuguese

Este produto cumpre com as normas da Diretiva Europeia 1999/5/EC.

Spanish

Este producto cumple con las normas del Directivo Europeo 1999/5/EC.

Swedish

Denna produkt har tillverkats i enlighet med EG-direktiv 1999/5/EC.

Local Restrictions of 802.11 a/b/g Radio Usage

CAUTION: Due to the fact that the frequencies used by 802.11 a/b/g wireless LAN devices may not yet be harmonized in all countries, 802.11 a/b/g products are designed for use only in specific countries or regions, and is not allowed to be operated in countries or regions other than those of designated use. As a user of these products, you are responsible for ensuring that the products are used only in the countries or regions for which they were intended and for verifying that they are configured with the correct selection of frequency and channel for the country or region of use. Any deviation from permissible settings and restrictions in the country or region of use could be an infringement of local law and may be punished as such.

The European variant is intended for use throughout the European Economic Area. However, authorization for use is further restricted in particular countries or regions within countries, as follows:

General

European standards dictate maximum radiated transmit power of 100 mW Effective Isotropic Radiated Power (EIRP) and the frequency range 2400 – 2483.5 MHz.

Belgium and the Netherlands

In Belgium and the Netherlands, the product may not be used outdoors. See the instructions next under the heading "Turning Off the Wireless LAN Radio."

France

Departments in Which the Wireless LAN Module Can Be Used (Indoors Only)

The wireless LAN module can currently be used indoors only in the following 38 departments of mainland France. Please turn off your wireless LAN radio when operating the device in areas/places other than the 38 departments listed:

| | | | | | |
|----|----------------|----|---------------------|----|-----------------------|
| 01 | Ain Orientales | 36 | Indre | 66 | Pyrénées |
| 02 | Aisne | 37 | Indre et Loire | 67 | Bas Rhin |
| 03 | Allier | 41 | Loir et Cher | 68 | Haut Rhin |
| 05 | Hautes Alpes | 42 | Loire | 70 | Haute Saône |
| 08 | Ardennes | 45 | Loiret | 71 | Saône et Loire |
| 09 | Ariège | 50 | Manche | 75 | Paris |
| 11 | Aude | 55 | Meuse | 82 | Tarn et Garonne |
| 12 | Aveyron | 58 | Nièvre | 84 | Vaucluse |
| 16 | Charente | 59 | Nord | 88 | Vosges |
| 24 | Dordogne | 60 | Oise | 89 | Yonne |
| 25 | Doubs | 61 | Orne | 90 | Territoire de Belfort |
| 26 | Drôme | 63 | Puy du Dôme | 94 | Val de Marne |
| 32 | Gers | 64 | Pyrénées Atlantique | | |

Departments in Which the Wireless LAN Module's Maximum EIRP Not Shown in the Previous Table

| Frequency Ranges (MHz) | Indoors | Outdoors |
|------------------------|---------|--|
| 2400 – 2446.5 | 10 mW | Not permitted |
| 2446.5 – 2483.5 | 100 mW | 100 mW on private property with Ministry of Defense approval |

Turning Off the Wireless LAN Radio

NOTE: Turning the wireless LAN radio off is not the same as disabling the wireless LAN card. It is not necessary to disable the card to meet the regulatory requirements.

While operating the computer in those French departments that do not allow use of the wireless LAN equipment, the user of the equipment must turn off the wireless LAN radio in order to comply with local regulations (see Chapter 2 for more information).